

Beverage Dispensers

Mini, Standard, Heated, Whipper and Super Bowl Models

Service Manual

Table of Contents

Unpacking	2
Installation	2
Assembly	3-4
Disassembly	5
Routine Maintenance	6
Helpful Hints	6
Preventative Maintenance	7
Security Kit Installation	8-9
Service	
Base Assembly Components	10
Installing Pump & Fan Motors	10
Replacement of Compressor	
Overload and Relay	10
Replacement of Temperature Control ..	11
Magnetic Lock	12
Evaporator Assembly	12
Refrigeration Test	12
Trouble Shooting Guide	13
Exploded Views	14-19
Wiring Diagrams	20-24
Refrigeration	
Schematic	25
Cap Tube Specs	25
Refrigerant Charges	25

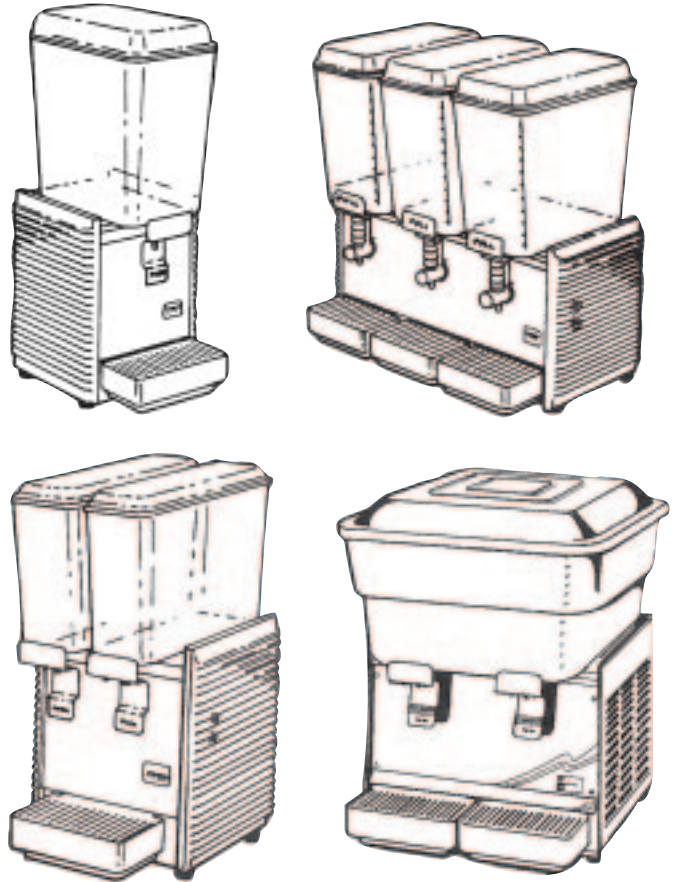

Prior authorization must be obtained from Grindmaster Corporation for all warranty claims.



Grindmaster Corporation™

4003 Collins Lane

Louisville, KY 40245 USA

(502) 425-4776 (800) 695-4500

(800) 568-5715 (Technical Service Only)

FAX (502) 425-4776

www.grindmaster.com

SET-UP

UNPACKING

Your dispenser is packed in 2 cartons: base pack and bowl pack. Unpack base by opening bottom flaps. See Figure A.

IMPORTANT NOTES:

1. Do not leave base upside down as this can damage refrigeration system.
2. Check that all 4 rubber feet are attached to legs after removing from base pad. Check base pad or carton for missing feet and replace on legs.
3. Never lift from louvres/ventilation slots. Instead, place fingers under base plate.

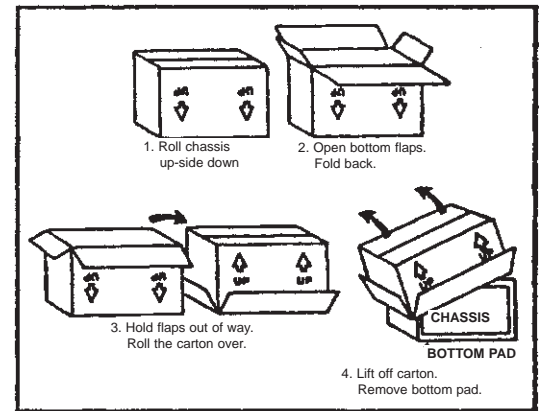

Figure A

INSTALLATION

1. Place base on counter.
2. For heated units (HD15/WHD15) units only:
Install Safety Arms
Tools required: Phillips Head Screwdriver
 - a) Place unit on its side so you have access to the bottom of the unit.
 - b) Line up arm holes so they line up to the holes on the bottom of the unit; arms will extend forward as shown in illustration. See Figure B.
 - c) Attach arms with screws provided.
3. Leave sufficient air space (6"(15cm)) on sides (also rear of D35 triple) for proper airflow and efficient operation. See Figure C.
IMPORTANT: Failure to provide required airspace can damage unit.
4. Plug into properly grounded, 3 prong outlet.
5. Assemble bowl parts and drain trays. See Assembly instructions that follow.
See Figure D.

NOTE: See pages 8 - 9 for Installing Security Kit Instructions.

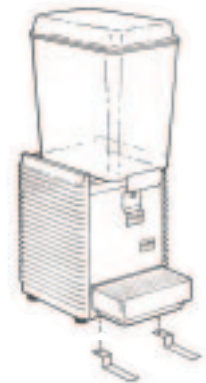

Figure B

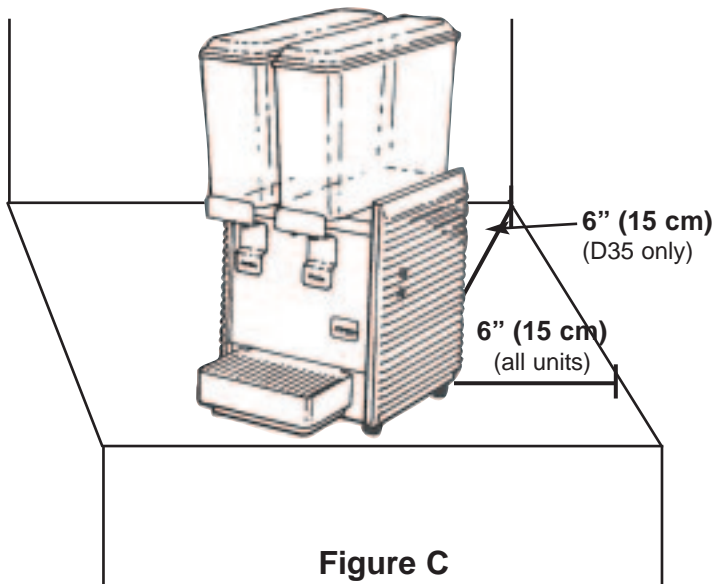

Figure C

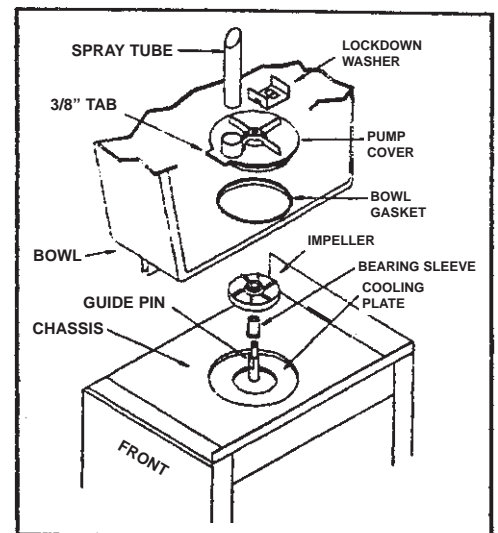
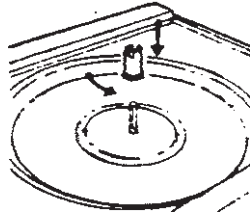

Figure D

Assembly

1 PLACE BEARING SLEEVE ON GUIDE PIN

Note flat sides on outside of guide pin and on inside of bearing sleeve.
Line flat sides up until bearing sleeve slides down over guide pin and rests on the cooling plate.



2 PLACE IMPELLER OVER BEARING SLEEVE.

Put impeller over bearing sleeve with fin side up.

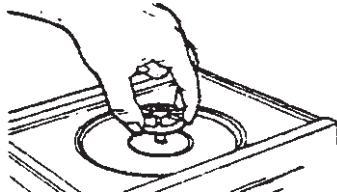

3 PLACE BOWL GASKET ON BOWL

Turn bowl upside down and place bowl gasket over the neck of the bowl. Moisten gasket with water.

NOTE: On D112 units place bowl gasket around cooling dome.

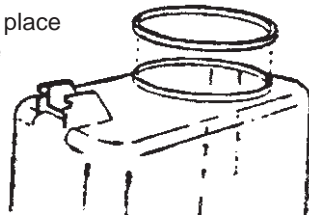

4 PUT BOWL ON BASE

Place the neck of the bowl over center of the cooling plate and with a back and forth downward motion, push bowl down into place.

NOTE: On D112 units, place bowl over the gasket and cooling dome with the neck of the bowl centered on the cooling dome.

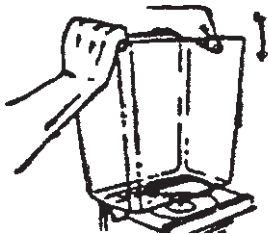

5 PLACE PUMP COVER OVER GUIDE PIN

Place the pump cover over the guide pin with the spray tube toward the front. Note that the tab on the front of the pump cover fits between the 2 locator buttons on the bowl. Mini units - bent part of spray tube faces front of bowl.

NOTE: Use agitator cover in place of pump cover and spray tube for fresh juice, drinks that foam (iced tea or dairy products), or heavy viscous drinks.

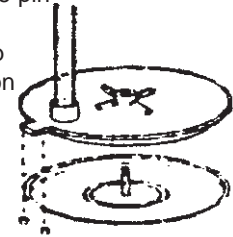

6 INSTALL LOCKDOWN WASHER OR CLAMPS

Standard Units:

- Place lockdown washer over guide pin.
- Push lockdown washer down and into locking keyway.
- Turn lockdown washer clockwise to lock into place.

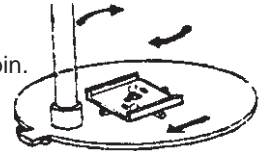

Mini Units:

- Place lockdown washer over guide pin.
- Push lockdown washer down and into locking keyway.
- Slide into locked position.

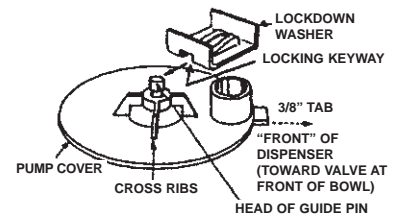

D112 Superbowl Units:

- Insert each lockdown clamp in a lockdown pin and snap down into place. (Lock down 2 clamps closest to the front of the bowl first.)

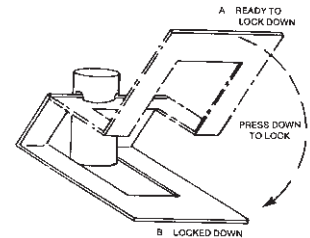

7 ASSEMBLE VALVE AND HANDLE

Place handle (C) in the two V-cuts in the front of the handle bracket (B) and push handle back. From inside bowl, lower the valve (A) through the outlet hole, and through the hole in the handle. Release handle.

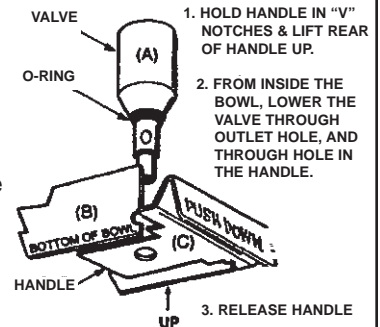

8 REPLACE DRIP PAN(S)

Lower pan cover into the top of the drip pan. Place top edge of drip pan up under lip on front panel. Lower each drip pan so that the tab goes down into the tab slot and locks pan in place.

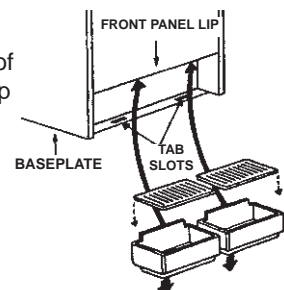

Regular units proceed to step 15.
Whipper units proceed to step 9.

Assembly (cont.)

9 PRESS SPRING UP INTO PLACE AGAINST THE BOTTOM OF THE BOWL.

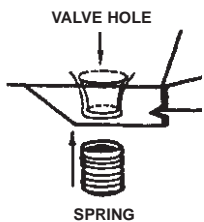

10 INSERT HANDLE INTO "V" NOTCHES AND PLACE VALVE INTO HOLE.

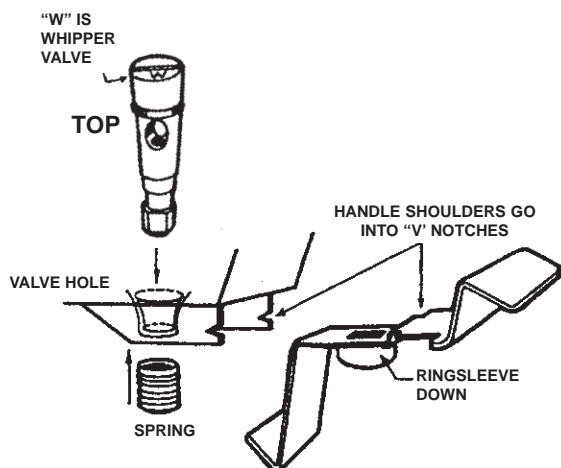

14 ASSEMBLE THE RUBBER INLET ADAPTER

Assemble white rubber inlet adapter by stretching one end over the large tubular inlet on top of the whipper housing. Attach the other end over the ring sleeve on the underside of the handle.

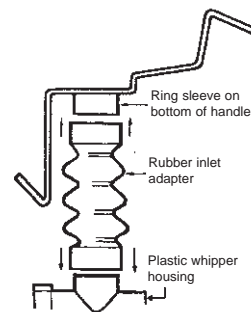

15 FILL BOWLS WITH PRODUCT and replace lids on bowls. Turn spray switch on first then refrigeration.

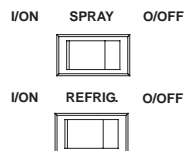

11 TURN VALVE 90° TO LOCK. Cross slot (located on top of valve) should run left to right across the bowl when locked.

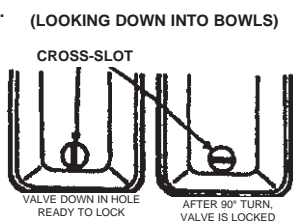

12 PUSH WHIPPER BLADE INTO PLACE. Replace the whipper blade by lining up the flat inside the blade with the flat side of the motor shaft. Push blade firmly into place.



13 REPLACE WHIPPER CHAMBER. Replace whipper chamber by positioning the medium-sized opening up and tilting 1/8 turn to the right. Put whipper chamber over whipper blade and turn to the left until it locks into place.



DISASSEMBLY

1 DRAIN ALL BEVERAGE FROM BOWLS

- A. Remove bowl lid(s) and drip tray(s)
- B. Drain through valve then
- C. Tip unit forward, gently press spray tube back a short distance to lift the edge of the pump cover to allow remaining beverage in well to be drained through valve.

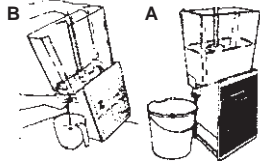

4 REMOVE PUMP COVER

Remove pump cover by lifting up on spray tube.

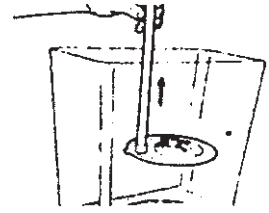

2a.

STANDARD & MINI UNITS:
REMOVE VALVE AND HANDLE
Lift valve. Handle drops into operator's other hand.

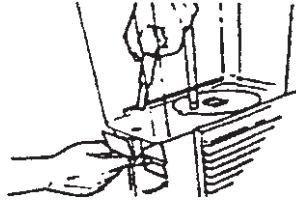

2b.

WHIPPER UNITS:

- DISASSEMBLE THE RUBBER INLET ADAPTER

Remove one end from the large tubular inlet on top of the whipper housing and the other end from the ring sleeve on the underside of the handle.

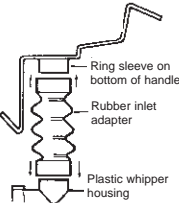

- REMOVE WHIPPER CHAMBER

Turn whipper chamber to the right until it releases and you can pull it off of the whipper blade.



- REMOVE WHIPPER BLADE

Pull whipper blade off of the motor shaft.



- TURN VALVE 90° TO UNLOCK.
REMOVE HANDLE AND VALVE.

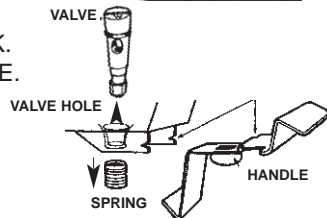

- REMOVE SPRING FROM BOTTOM OF BOWL.

3 REMOVE LOCKDOWN WASHER(S)

Standard Unit: Twist lockdown washer counterclockwise, slide to release keyway. Then lift out.

Mini Unit: Slide to release keyway, then lift out.

D112 Unit: Release each clamp.

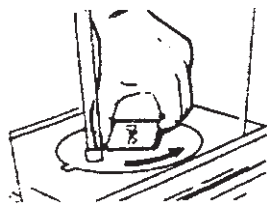

5 REMOVE BOWL AND BOWL GASKET

Twist bowl back and forth while lifting up. Bowl gasket will be around bottom of bowl.
NOTE: On D112 units, bowl gasket will be around cooling dome.

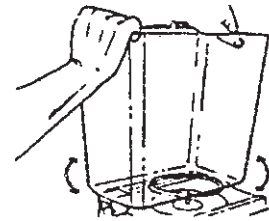

6 REMOVE IMPELLER AND BEARING SLEEVE

Remove impeller and bearing sleeve by lifting them straight up.

NOTE: Check impeller and bearing sleeves for wear. See page 7.

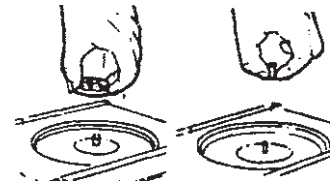

7 THOROUGHLY CLEAN ALL PARTS IN WARM WATER USING A MILD NON-ABRASIVE DETERGENT AND RINSE THOROUGHLY.

CAUTION: ABRASIVES WILL SCRATCH PLASTIC PARTS. WASH BOWL LIDS IN COOL OR LUKEWARM WATER TO AVOID LEAKS DUE TO SEALED SURFACE BEING DAMAGED.

SANITIZE

Immerse parts in sanitizing solution for 1-2 minutes. Remove parts from sanitizing solution and drain. **DO NOT RINSE.** Place parts on a clean surface to air dry. Wipe the machine, condensate tray and cooling plate depression with a cloth wetted with sanitizer solution.

IMPORTANT: Never pour dry powder, crystals, or concentrate into a dry bowl. Premixing beverage in separate container is recommended. If mixing in bowl, always add water first.

ROUTINE MAINTENANCE: For all Models

Cleaning Your Dispenser

To optimize performance or when using dairy products, clean unit daily.

Regular cleaning of bowl components will result in maximum pumping efficiency, proper seating and sealing, and prevention of leaks at the valve O-Ring and bowl gasket by removing dried-on beverage solids and pulp from moving sealed parts.

1. Wash all bowl components regularly. Follow all local health codes.
 - * Refer to Disassembly, Cleaning, and Assembly instructions on pages 3-4.

Sanitizing Your Dispenser

* Refer to Disassembly and Assembly instructions on pages 3-4.

1. In the bowl, mix one gallon of Oxford Chemical's Disinfectant/Sanitizer Formula C or its equivalent.
2. Turn on spray motor(s) and allow sanitizer to spray around inside of bowl for a period of time as recommended by the sanitizer manufacturer. Formula C is satisfactory for this purpose when mixed in a solution of 1 liquid ounce of cleaner to 4 gallons of water. Run spray motor(s) for 60 seconds. In areas with extreme hard water, consult the local health authority.
3. Drain sanitizer **completely** and **thoroughly** during each step of the cleaning process (wash, rinse, and sanitize). Refer to tips on draining in Disassembly Guide on page 3.

HELPFUL HINTS

1. **Noisy Impeller:** Do not run impeller dry. The impeller will make a chattering sound in an empty bowl. Remove the impeller and run a small amount of water in the bowl.
2. **Valve and O-Ring:** On the first installation, if there is an after-drip, place your hand on the valve and with a slight downward pressure turn it slightly. This will help seat the o-ring so that it is properly aligned with the valve seat. If an o-ring becomes cut or worn it should be replaced. If you are pumping a product which has excessive pulp, a separate valve weight may be purchased to add extra weight so the o-ring will press down against the pulp and guarantee a positive shut-off.
3. **Valve Cap Use:** The Valve Cap (Part # 2039) insures that a tight valve seal will occur with products containing heavy pulp. The Valve Cap can be installed by placing it on top of the Valve after the Valve has been assembled into the bowl. See Figure E.
4. **High Water Marks on Bowl:** When you agitate, you may get "high water marks" as the beverage level drops. Keep the bowl as full as possible. Frosted bowls are available which are helpful in reducing the appearance of water marks.
5. **To Spray or Not to Spray:** Most beverages can be sprayed. It is best not to spray iced tea, iced coffee, natural juices, or beverages that foam (whipped drinks). A special agitator plate is used in place of a pump cover and spray tube to promote circulation.
6. **Proper Cooling:** Always keep spray switch on when refrigeration switch is on. A unit must spray or agitate to cool. Failure to do this will cause impeller to lock-up. The dispenser is designed to run 24 hours a day. Keep both spray and agitate on when beverage is in the bowls.
7. **Condensation:** Condensation on the bowls and lids is natural, cool, and refreshing. The amount of condensation is affected by humidity. Condensation will run down the front panel into the drip tray. Remember to occasionally empty the drip trays.
8. **Single Bowl Operation:** If you find it necessary to run your dispenser with only one bowl containing beverage, put one half (1/2) cup of water in the unused cooling plate depression(s) for best one-bowl operation and efficiency.

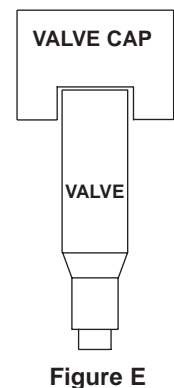

Figure E

PREVENTATIVE MAINTENANCE

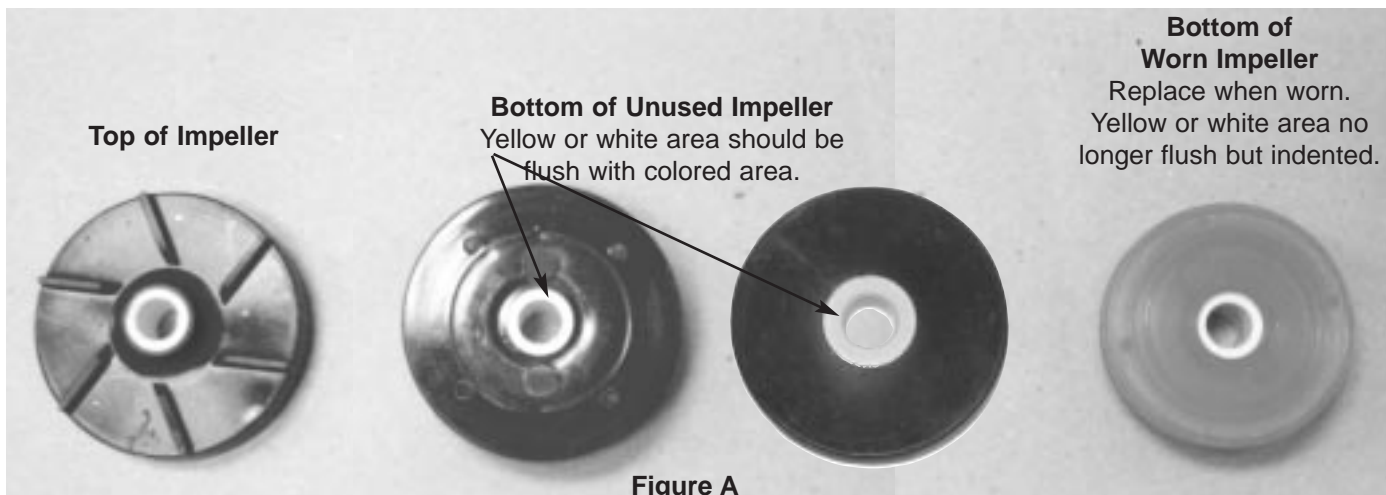
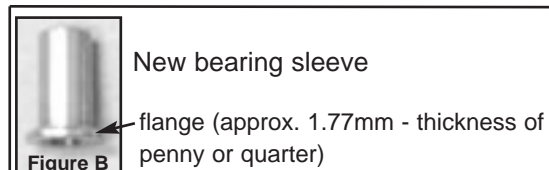

Figure A

- 1) Wash all bowl components regularly.
- 2) Wash impeller and bearing sleeve individually and check for wear.
 - a) Check for wear on bearing sleeve (flange should be 1.77mm thick - thickness of penny or quarter). (Figure B)
 - b) Check for wear on impeller (inner white center section should be flush with colored part of impeller). (Figure A)
 - c) If bearing sleeve or impeller do not spin freely or are worn - replace them. (Figure E)
 - d) Worn parts can cause personal injury, impair cooling and can damage machine. (Figure C & D)
- 3) Check valve o-rings and bowl gaskets for wear or damage - replace every 6 months or as needed.
- 4) Every 6 months or more often if needed: unplug unit, remove panels, clean condenser and interior. (Remove dust and lint from fins with a soft brush and vacuum.)
- 5) For further information, visit www.grindmaster.com or call (800) 695-4500.



New bearing sleeve

Figure B

flange (approx. 1.77mm - thickness of penny or quarter)

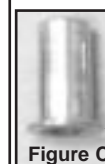

Worn bearing sleeve (replace when worn to approx. 1mm or 1/2 thickness of penny or quarter).

Figure C

worn flange

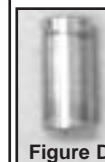

Bearing sleeve with flange missing is extremely worn. Discard immediately.

Figure D

CAUTION: Handle with care. Sharp edges may cause personal injury or damage to machine.

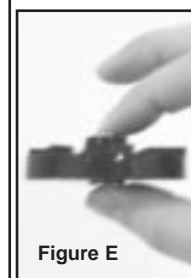

Figure E

Bearing sleeve and impeller should spin freely when held like this. If parts do not spin freely or are worn, unit will not cool properly and worn parts may damage machine.

Part #s for Preventative Maintenance	
Description	Part #
Bearing Sleeve (all units except D112)	3220
Large Blue Impeller (D & WD model)	1161
Small Red Impeller (E model)	1008
Universal Impeller (all models)	3587
Valve O-ring	1012
Bowl Gasket - for D, WD models 5 gallon (or 3 gallon) bowl	1013
Bowl Gasket for E model and/or 9 liter bowl	2010
Bowl Gasket for 12 gallon SuperBowls (D112)	1150
Bearing Sleeve for 12 gallon Super Bowl (D112)	1983



Universal Impeller (Part # 3587)

SECURITY KIT INSTALLATION - STANDARD UNITS

The valve security kit locks dispenser valve to prevent use when store is closed. The bowl security kit locks the lid on the bowl to prevent unauthorized access.

Standard Security Kit Includes

	D15	D25	D35
ITEM	PART # / QTY	PART # / QTY	PART # / QTY
KIT (contents listed below)	2509	2510	2511
PAD LOCK	1503 / (2)	1503 / (3)	1503 / (4)
COVER LOCK STRAP	2450 / (2)	2451 / (2)	2450 / (2)
VALVE LOCKING BOX	2502 / (1)	2502 / (2)	2502 / (3)
KEY VALVE LOCKING BOX	2503 / (1)	2503 / (2)	2503 / (3)
CHANNEL TOP	N/A	N/A	2554 / (1)

How to Assemble Bowl Locking Strap

No tools are needed to assemble kit. One pair of *Cover Lock Straps* are needed per dispenser. They are designed to work on 5 gallon bowls only with the double wall bowl cover #2240. Each pair of cover straps uses one *Padlock*. The Model D35 triple bowl unit also requires a top channel bar. UNPLUG MACHINE BEFORE INSTALLING KIT

1) **For - 3 Models** (with stainless side panels), hook the bottom end of the strap into the louvre in the top row nearest the dispenser's front on both sides of the dispenser. (See Figure 1)

For - 4 Models (with plastic side panels), hook the bottom end of the strap under the second section* of the top louvre on both sides of the dispenser. (*note the sections under the louvres)(See Figure 1)

2) Bring both tops of the cover straps together (above the bowl cover).
3) Place padlock into the holes of the cover straps and lock together.

Note: D35 only - The top channel is interlocked into place on top of the bowls in the same manner as described above. Interlock the side without the padlock first. (See Figure 2)

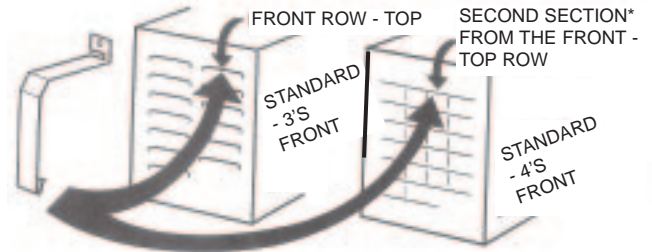

Figure 1

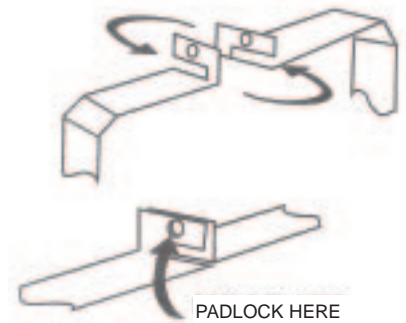

Figure 2

Valve Box Locking Installation Instructions for Standard Units

The extended side of the box with the turned-up edge is the top.

- 1) Place the turned up edge (#1) over the top edge of the handle.
- 2) Place #2 behind the "Push" part of the handle.
- 3) Next, raise the box while keeping it pressed against the front panel of the dispenser. Hook the turned-up edge (#1) over the top of the handle.
- 4) Slide the locking bar (#3), through the slots (#4).
- 5) Add the padlock through the hole and lock.

NOTE: Kit designed for "cup activated" handle (pictured). Kit will not work with "non-contact" handle.

SECURITY KIT INSTALLATION - MINI MODELS

The valve security kit locks dispense valve to prevent use when store is closed. The bowl security kit locks the lid on the bowl to prevent unauthorized access.

Mini Security Kit Includes

	E27	E29	E47	E49
ITEM	PART # / QTY	PART # / QTY	PART # / QTY	PART # / QTY
KIT (contents listed below)	5350	5351	5352	5353
SECURITY BRACKET	2755 / (1)	2755 / (1)	2755 / (1)	2755 / (1)
SECURITY UPRIGHT	2756 / (1)	2943 / (1)	2756 / (1)	2943 / (1)
LOCKDOWN CHANNEL	2760 / (1)	2760 / (1)	2761 / (1)	2761 / (1)
SCREW, 10-24 X 3/4	0077 / (1)	0077 / (1)	0077 / (1)	0077 / (1)
PADLOCK	1503 / (2)	1503 / (2)	1503 / (3)	1503 / (3)
VALVE LOCKING BOX	3203 / (2)	3203 / (2)	3203 / (4)	3203 / (4)
LOCKING BAR	3202 / (1)	3202 / (1)	3202 / (2)	3202 / (2)
CAP NUT	0053 / (2)	0053 / (2)	0053 / (2)	0053 / (2)
5/16 SS SCREW	0061 / (2)	0061 / (2)	0061 / (2)	0061 / (2)
SECURITY CLAMP	2754 / (1)	2754 / (1)	2754 / (1)	2754 / (1)

Tools required: 1 regular blade screwdriver,
1 Phillips screwdriver

Instructions:

UNPLUG MACHINE BEFORE INSTALLATION

- 1) Remove all bowls from unit.
- 2) Remove the left side panel and back panel.
- 3) Clip security bracket over the back lip of top tray between the bowl indentations. (see drawing)
- 4) Reassemble back and side panel. The back panel fits over the security bracket.
- 5) Situate the security clamp over the drip lip and tighten the screw (#0077), so the tab, located on the back of the security clamp, slides into the security bracket's slot. (see drawing)
- 6) Bolt the security upright onto the security clamp using 2 cap nuts and 5/16 SS screws provided. (see drawing)
- 7) Reassemble the bowls on the unit.
- 8) Place the lockdown channel on top of bowls, making sure the lockdown channel's opening slips into the security upright's notch.

Valve Locking Device Installation Steps

- 1) Place locking box underneath bowl where valve protrudes.
 - 2) Insert locking bar through the slits on each side of the locking box.
 - For Models E27 and E29 put the locking bar through both boxes.
 - For Models E47 and E49 put the locking bar through two of the locking boxes from the center with the lock on the outside.
 Next, install the two other boxes from the outside to the center.
 - 3) Place the padlocks into the hole on each locking bar and lock.
- NOTE:** Kit designed for "cup activated" handle (pictured). Kit will not work with "non-contact" handle.

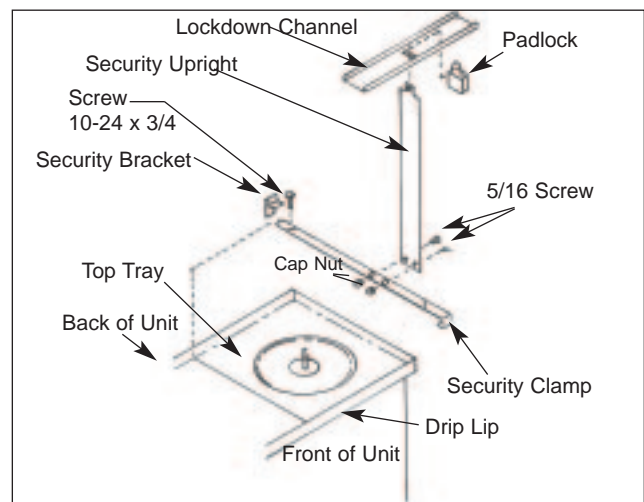

Mini Model Valve Locking Device Exploded View

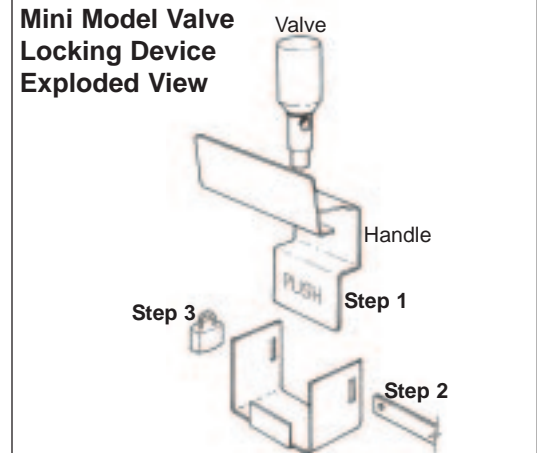

SERVICE

BASE ASSEMBLY COMPONENTS (Refrigerated Unit)

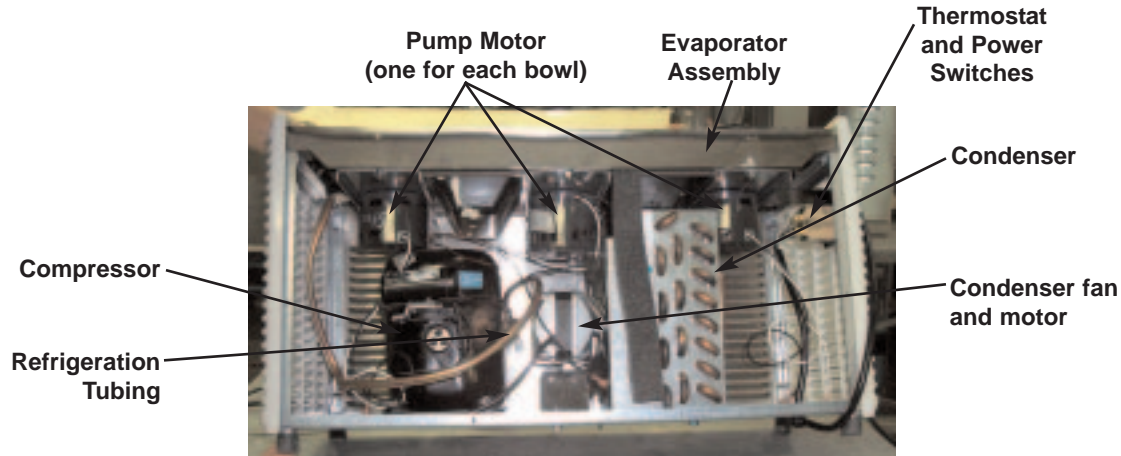

(Model D35 shown here)

INSTALLING PUMP AND FAN MOTORS: For All Models

Tools Required: Phillips screwdriver

1. Disconnect from power.
2. Remove cabinet panels.
3. Disconnect wires leading from motor to terminal board and/or switch.
4. Loosen bolts holding motor in place and replace with new motor.

NOTE: Loosen bolts that hold top tray to frames for easier pump motor installation. Retighten bolts after reassembly.

5. Connect wires from new motor to terminal board and switch.
6. Replace cabinet panels.

NOTE: When installing or repairing the pump it is important to adjust the magnetic lock. On page 5 are the instructions that should be followed for adjusting the magnetic lock (See Figure N).

REPLACEMENT OF COMPRESSOR OVERLOAD AND RELAY: (Figure Q)

For Standard, Whipper and Mini Models

1. Disconnect from power and remove front panel.
2. Remove plastic cover (A) and lock wire (E27s have a nut to unscrew) (B) from compressor housing and note positions of overload (C), relay (D) and wiring.
3. Disconnect overload (C) from housing and wires, put overload spring clip (E) on new overload, then rewire and replace in proper position on compressor.
4. Pull off relay (D) and disconnect wires, then rewire and push new relay onto the compressor terminals (F).
5. Replace plastic cover (A) and lock wire (B), front panel of dispenser and service cord to power supply.

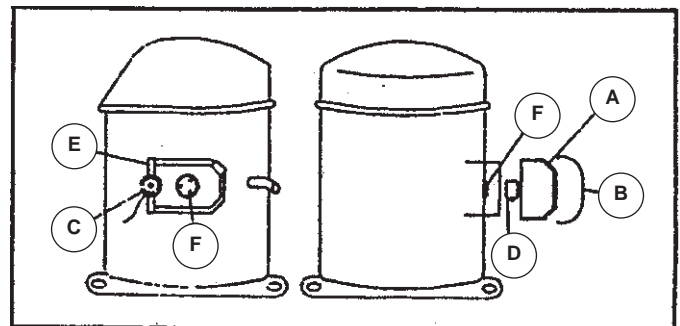

Figure Q

REPLACEMENT OF TEMPERATURE CONTROL (PART # 1059)

Tools Required: Phillips Screwdriver; Grease or Petroleum Jelly; Putty or similar substance

1. Unplug unit.
2. Remove front panel and side panel, located on the switch side, to access the temperature control mounting screws, located on the front right corner of the frame.
3. Remove the two (2) terminals to the control. Remove the two (2) screws holding the control to the frame.
4. Pull the control tube out of the evaporator, noting its direction and length it was inserted into the evaporator.
5. Straighten the new tube out and lubricate it with grease or petroleum jelly if possible.
6. Slide the control into the copper tube inside the evaporator.
7. Make sure the control slides into the tube the same distance as the old one. Reseal the opening with putty or a similar substance.
8. Bend excess tubing away from the fan blade.
9. Reassemble the terminals, screws and panels.
10. The control is in approximate calibration and the bowl temperature should be between 35 and 40 degrees. Minor adjustments can be made by turning the cut in/cut out adjustments screws on the control side.

TEMPERATURE CONTROLLER

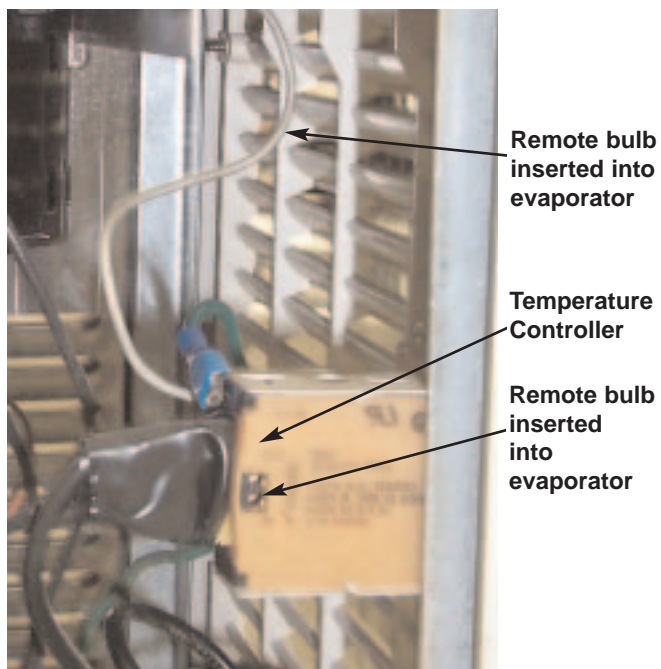

EVAPORATOR TRAY

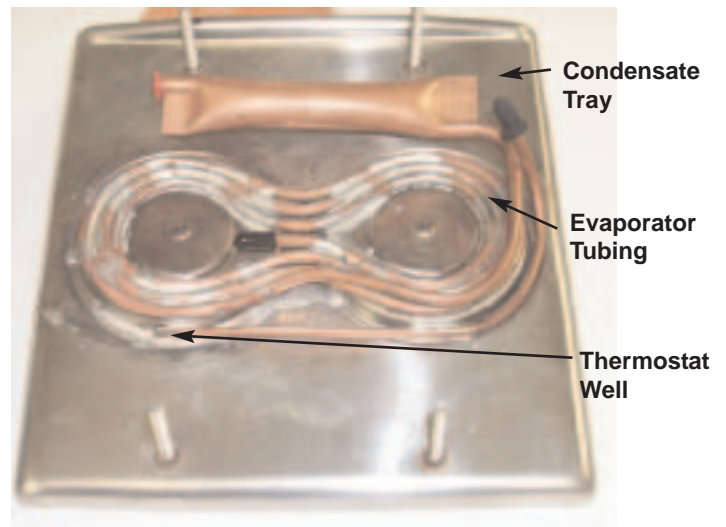

MAGNETIC LOCK

Magnetic Lock Problems

If a unit is not spraying, check the following:

- a) The impeller must spin freely when the bearing sleeve is held between the thumb and the forefinger,
- b) The impeller should turn when assembled and the motor switch is turned "ON".
- c) The pump motor runs without the impeller in place.
- d) The air-gap between the drive magnet and the impeller is too great, causing a loss of "magnetic lock".

NOTE: When adjusting the drive magnet on the pump motor shaft, place the drive magnet assembly as high as possible and still leave 1/16" clearance between the magnet and the underside of the top tray. The spacers on the motor bracket may be removed first for easier access.

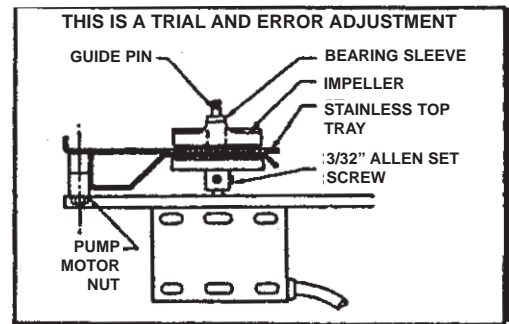

Figure N

Magnetic Lock Adjustment

1. Remove the pump motor assembly from the unit by loosening the (2) pump motor bolts with a 7/16 wrench. (To remove the left pump motor assembly on a D25, you will have to remove the (2) bolts that connect the frame to the top tray on the left side and raise the frame slightly to slide the motor out.)
2. With a 3/32 Allen Wrench, loosen the (2) set-screws on the drive magnet and raise the magnet. The magnet should be as close as possible to the evaporator cover without rubbing. Tighten the set-screws and replace the pump motor assembly.

TOP TRAY ASSEMBLY STEPS (EVAPORATOR ASSEMBLY)

1. Unplug the unit.
2. Remove all panels.
3. Remove 4 tray mounting bolts in upper corners.
4. Evacuate refrigerant.
5. Disconnect pump motor wires.
6. Unsolder suction line and capillary tube.
7. Replace filter drier.
8. Swap pump motor assemblies to new evaporator assembly.
9. Reassemble.
10. Evacuate and charge system.

REFRIGERATION TEST

2. Turn unit ON - if refrigeration is OK a frost pattern will form in less than 5 minutes.

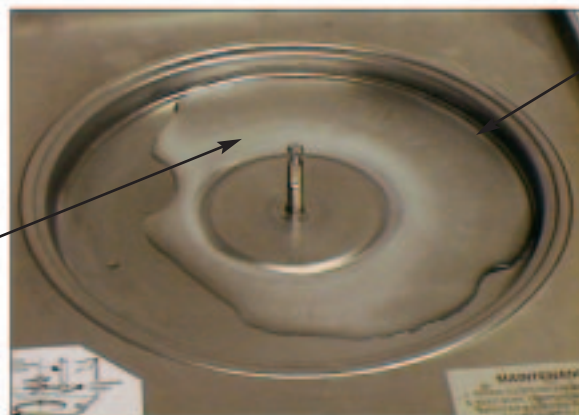

1. Add water to well.

Trouble Shooting Guide

PROBLEM	POSSIBLE CAUSE	SOLUTION
No or partial Refrigeration: Compressor Runs Note: Unit must spray or agitate properly to obtain cooling	<ul style="list-style-type: none"> • Not clear air flow • Condenser clogged with dust or lint • Faulty fan motor • Loss of refrigerant • Fan blade hitting wires or tubing 	<ul style="list-style-type: none"> • Provide 6" clearance on sides and back • Remove front panel and clean out all lint and dust . Use vacuum cleaner or bottle brush. • Replace motor • Return to factory - call for RMA. • Bend wires or tubing to clear.
No Refrigeration: Compressor Does Not Run Note: Unit must spray or agitate properly to obtain cooling	<ul style="list-style-type: none"> • Defective compressor overload protector • Compressor cycles on overload protector • Faulty refrigeration switch • Temperature control open • Faulty electrical connection • After checking all of above, if compressor doesn't run 	<ul style="list-style-type: none"> • Replace. • Check for low line voltage. Then check relay and overload and replace if necessary. • Replace switch. • Replace temperature control. • Locate and correct. • Return to factory - call for RMA.
No Spray or Agitation: Spray Motor Runs	<ul style="list-style-type: none"> • Pump impeller does not spin; check for worn bearing sleeve and/or impeller (impeller rubbing on stainless steel evaporator) • Pump impeller does not spin freely on bearing sleeve. • Impeller chatters but does not spin properly 	<ul style="list-style-type: none"> • Replace sleeve and/or impeller. • Clean impeller bearing. Ream out impeller bearing if necessary. Impeller must spin freely on bearing sleeve. • Raise drive magnet higher on motor shaft, but not high enough to rub.
No Spray: Spray Motor Doesn't Run	<ul style="list-style-type: none"> • Loose electrical connection to motor • Faulty spray switch • Faulty motor • Drive magnet binds on plastic evaporator cover 	<ul style="list-style-type: none"> • Locate and correct • Replace spray switch • Replace motor • Relocate magnet (NOTE: Magnet should be about 1/16" from plastic to prevent binding or rubbing.)
Leaky Bowl	<ul style="list-style-type: none"> • Gasket improperly installed • Worn or nicked bowl gasket • Ordinary condensation build-up 	<ul style="list-style-type: none"> • Reinstall gasket. Check directions for bowl assembly. • Replace gasket • Keep drip pan attached to catch condensation.
Noisy Unit	<ul style="list-style-type: none"> • Worn bearings in either fan or pump motor • Bent fan blade • Pump impeller and/or sleeve chattering 	<ul style="list-style-type: none"> • Replace motor(s) • Re-bend fan blade to correct alignment • Replace impeller and/or sleeve
Unit Does Not Heat	<ul style="list-style-type: none"> • Loose electrical connection to heating element 	<ul style="list-style-type: none"> • Locate and correct
Unit Overheats	<ul style="list-style-type: none"> • Faulty thermostat 	<ul style="list-style-type: none"> • Replace thermostat

If you still need help, call an authorized dealer in your area or Grindmasher Corporation's Technical Service Department. You can reach Technical Service at (800) 425-4776 Monday-Friday, 8:00 AM-6:00 PM Eastern Standard Time. Please have the model and serial number ready so that accurate information can be given.

Prior authorization must be obtained from Grindmaster Corporation's Technical Service Department for all warranty claims.

Exploded View Standard and Whipper Models (D15, D25, D35, & WD)

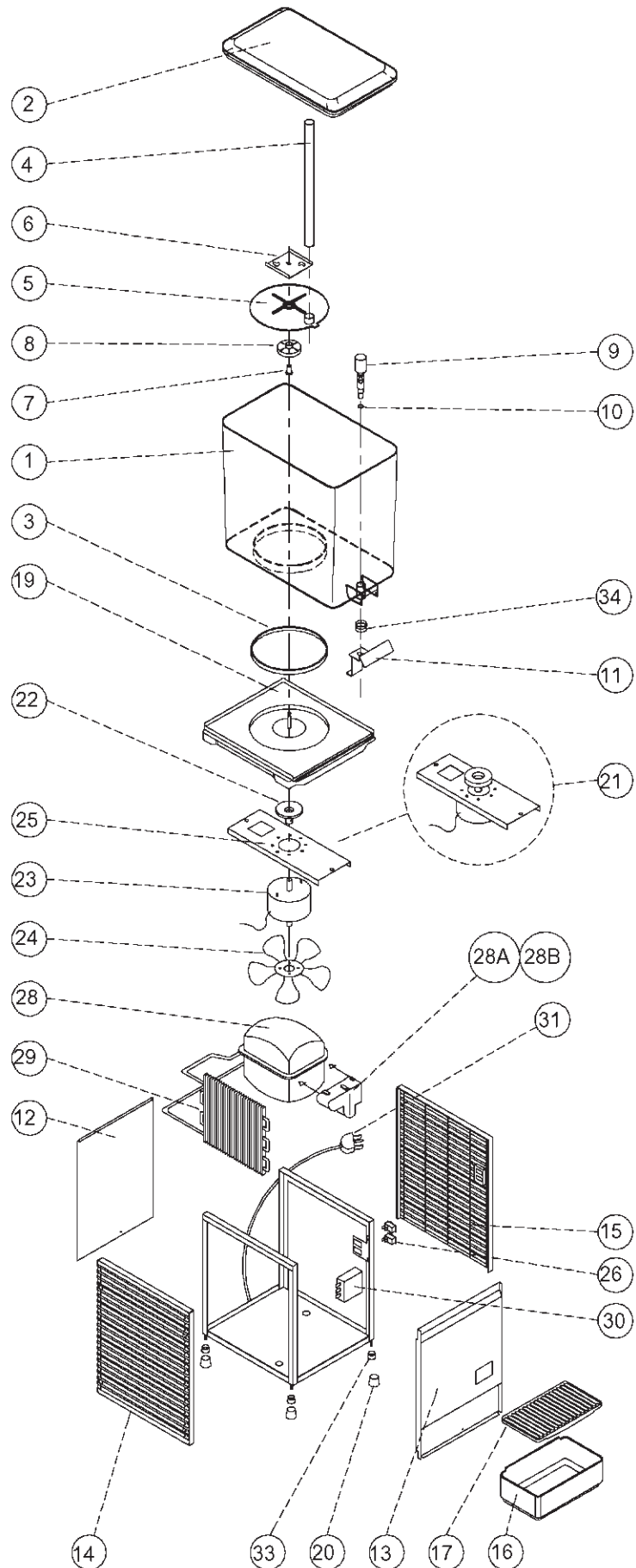

D25, D35, D255, D355, WD25,
WD35, WD255, AND WD355
FAN ASSEMBLY

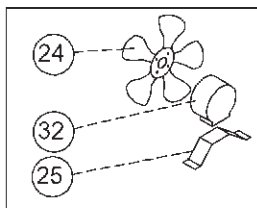

STANDARD D15 SHOWN

SOME COMPONENTS FOR THE
D25, D35, D255, D355
WD25, WD35, WD255 AND WD355
MAY BE IN DIFFERENT LOCATIONS
THAN ILLUSTRATED

Parts List Standard and Whipper Models

ITEM #	DESCRIPTION	D15	D25	D35	D155	D255	D355
		WD15 3/4	WD25 3/4	WD35 3/4	WD155 3/4	WD255 3/4	WD355 3/4
BOWL ASSEMBLY PARTS							
1	BOWL (5 GAL)	1288	1288	1288	1288	1288	1288
	BOWL (3 GAL)	1090	1090	1090	1090	1090	1090
2	BOWL COVER (SINGLE WALL)	1116	1116	1116	1116	1116	1116
	BOWL COVER (DOUBLE WALL)	2240	2240	2240	2240	2240	2240
3	BOWL GASKET	1013	1013	1013	1013	1013	1013
4	SPRAY TUBE (5 GAL)	1261	1261	1261	1261	1261	1261
	SPRAY TUBE (3 GAL)	1092	1092	1092	1092	1092	1092
5	PUMP COVER (RED OR BLACK IMPELLER) (USE W/ SPRAY TUBE)	1735	1735	1735	1735	1735	1735
	PUMP COVER (BLUE IMPELLER)	1741	1741	1741	1741	1741	1741
5	AGITATOR (RED OR BLACK IMPELLER) (CIRCULATES FROM BOTTOM)	1740	1740	1740	1740	1740	1740
	AGITATOR (BLUE IMPELLER)	1742	1742	1742	1742	1742	1742
6	WASHER (LOCK DOWN S.S.)	1734	1734	1734	1734	1734	1734
7	BEARING SLEEVE S.S.	3220	3220	3220	3220	3220	3220
8	IMPELLER, MAGNETIC, MOLDED	3587	3587	3587	3587	3587	3587
9	VALVE W/O'RING (STANDARD)	1010A	1010A	1010A	1010A	1010A	1010A
	VALVE W/ O'RING (WHIPPER)	2977A	2977A	2977A	2977A	2977A	2977A
10	O'RING FOR VALVE	1012	1012	1012	1012	1012	1012
11	HANDLE STANDARD (CUP ACTIVATED)	2266	2266	2266	2266	2266	2266
	HANDLE STANDARD (NON-CUP CONTACT)	2484	2484	2484	2484	2484	2484
	HANDLE - WHIPPER	2955	2955	2955	2955	2955	2955
34	SPRING - WHIPPER	1929	1929	1929	1929	1929	1929
CHASSIS CABINETRY							
12	BACK PANEL - STANDARD	2312	2280	2315	2312	2280	2315
	BACK PANEL - WHIPPER	2805	2356	2507	2805	2356	2507
13	FRONT PANEL - STANDARD	2640	2278	2276	2640	2278	2276
	FRONT PANEL 1 WHIPPER	2845	2350	2506	2845	2350	2506
	FRONT PANEL 2 WHIPPERS	N/A	2351	2505	N/A	2351	2505
	FRONT PANEL 3 WHIPPERS	N/A	N/A	2504	N/A	N/A	2504
14	LEFT SIDE PANEL -3 (STAINLESS STEEL)	2261	2261	2261	2261	2261	2261
	LEFT SIDE PANEL -4 (HIGH-IMPACT PLASTIC)	2270	2270	2270	2270	2270	2270
15	RIGHT SIDE PANEL -3 (STAINLESS STEEL)	3400	3401	3401	3400	3401	3401
	RIGHT SIDE PANEL -4 (HIGH-IMPACT PLASTIC)	3397	3398	3398	3397	3398	3398
16	DRIP PAN -3 (STAINLESS STEEL)	2243	2243	2243	2243	2243	2243
	DRIP PAN -4 (HIGH-IMPACT PLASTIC)	2231	2231	2231	2231	2231	2231
17	DRIP PAN COVER -3 (STAINLESS STEEL)	2305	2305	2305	2305	2205	2205
	DRIP PAN COVER -4 (HIGH-IMPACT PLASTIC)	2232	2232	2232	2232	2232	2232
19	TRAY (EVAP. ASSY) STANDARD	5641	2462	2463	5641	2462	2463
	TRAY (EVAP. ASSY) WHIPPER	5641	5552	5549	5641	5552	5549
20	LEG TIP (4)	1822	1822	1822	1822	1822	1822
33	LEG	1821	1821	1821	1821	1821	1821
ELECTRICAL COMPONENTS		(115-60)	(230-50)	(115-60)	(230-50)	(115-60)	(230-50)
(BOTH -3 & -4 UNITS)		D-15	D-155	D-25	D-255	D-35	D-355
		WD-15	WD-155	WD-25	WD-255	WD-35	WD-355
21	PUMP MTR & DRIVE ASSY (STANDARD)	1370	1956	1345	1955	1345	1955
	PUMP MTR & DRIVE ASSY (WHIPPER)	2113	3295	1345	1955	1345	1955
22	MAGNET DRIVE ASSY	1733	1733	1733	1733	1733	1733
23	PUMP MOTOR-ONLY (STANDARD)	1351	1594	1068	1122	1068	1122
	PUMP MOTOR-ONLY (WHIPPER)	1655	3287	1068	1122	1068	1122
32	FAN MOTOR-ONLY	N/A	N/A	1336	1584	1336	1584
24	FAN BLADE	1273	1273	1459	1459	1459	1459
25	FAN MOTOR BRACKET	N/A	N/A	3370	3370	1338	1338
26	ON / OFF SWITCH	3373	3373	3373	3373	3373	3373
28	COMPRESSOR 134A	3251	3247	3245	3250	3253	3248
28A	COMPRESSOR RELAY	2436	3308	3298	3299	2430	2998
28B	OVERLOAD	3301	2441	1179	3309	1487	2997
29	CONDENSER	3352	3352	3371	3371	3508	3508
30	TEMP CONTROL	1059	1059	1059	1059	1059	1059
31	SERVICE CORD	1072	1148*	1072	1148*	1205*	1148*

* NOT AVAILABLE FROM THAILAND

Standard Whipper Components

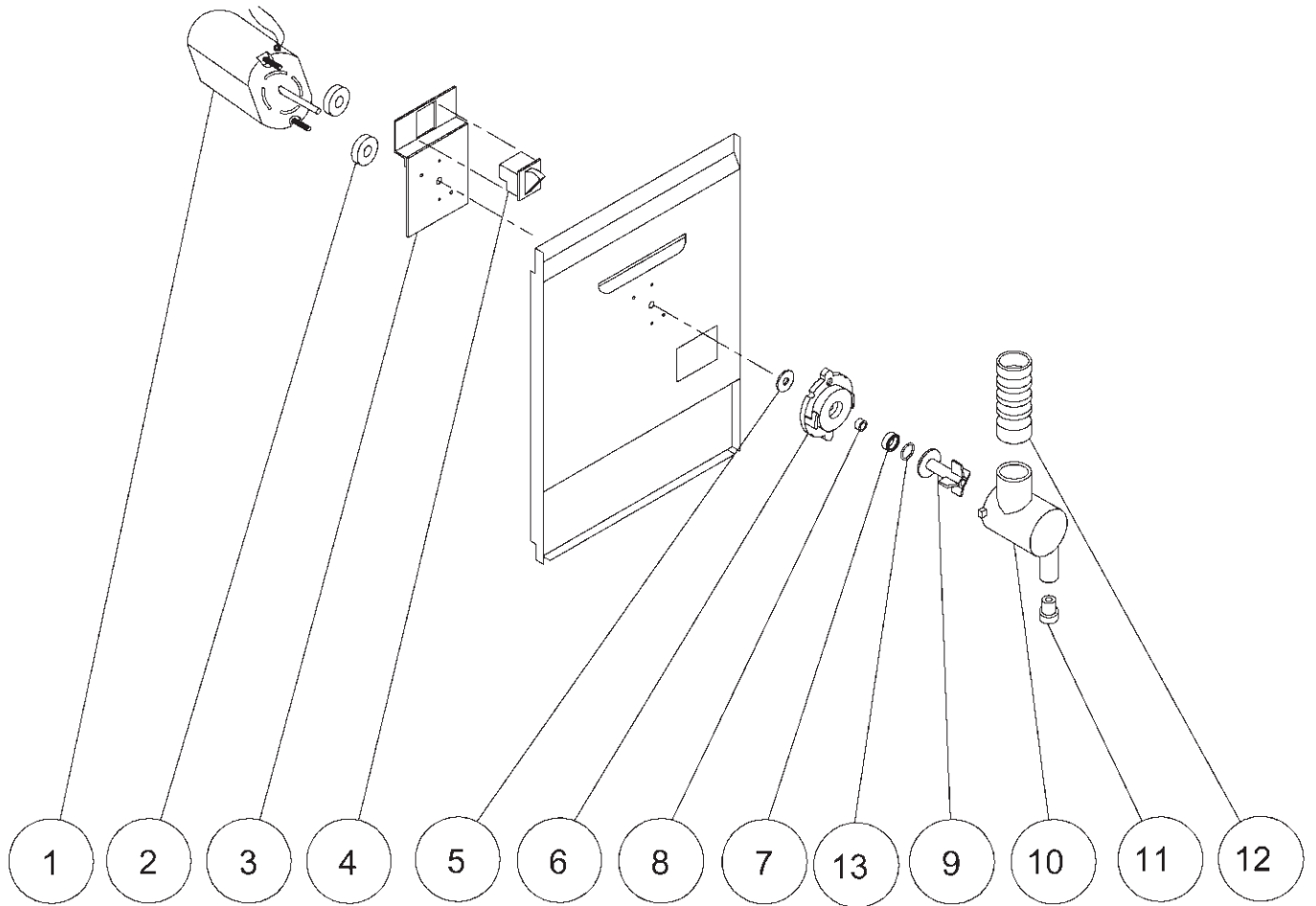

WHIPPER COMPONENTS

WHIPPER COMPONENTS (BOTH -3 & -4 UNITS)		(115-60) WD-15	(230-50) WD-155	(115-60) WD-25	(230-50) WD-255	(115-60) WD-35	(230-50) WD-355
1	WHIPPER PUMP MOTOR	1936	2092	1936	2092	1936	2092
2	PLATE BACK-UP SWITCH HOLDER	2358	2358	2358	2358	2358	2358
3	SWITCH ROCKER WHIPPER	1931	1931	1931	1931	1931	1931
4	WASHER SLINGER (HARD)	2979	2979	2979	2979	2979	2979
5	BASE WHIPPER (WITH SEAL)	2982A	2982A	2982A	2982A	2982A	2982A
6	BEARING, WHIPPER	3503	3503	3503	3503	3503	3503
7	IMPELLER (4-BLADE)	1980	1980	1980	1980	1980	1980
8	HOUSING BLENDER	1298	1298	1298	1298	1298	1298
9	HOUSING BUTTON	1416	1416	1416	1416	1416	1416
10	ADAPTER INLET WHIPPER	2497	2497	2497	2497	2497	2497
11	O-RING	2981	2981	2981	2981	2981	2981

Exploded View Mini Models (E27/9 or E47/9)

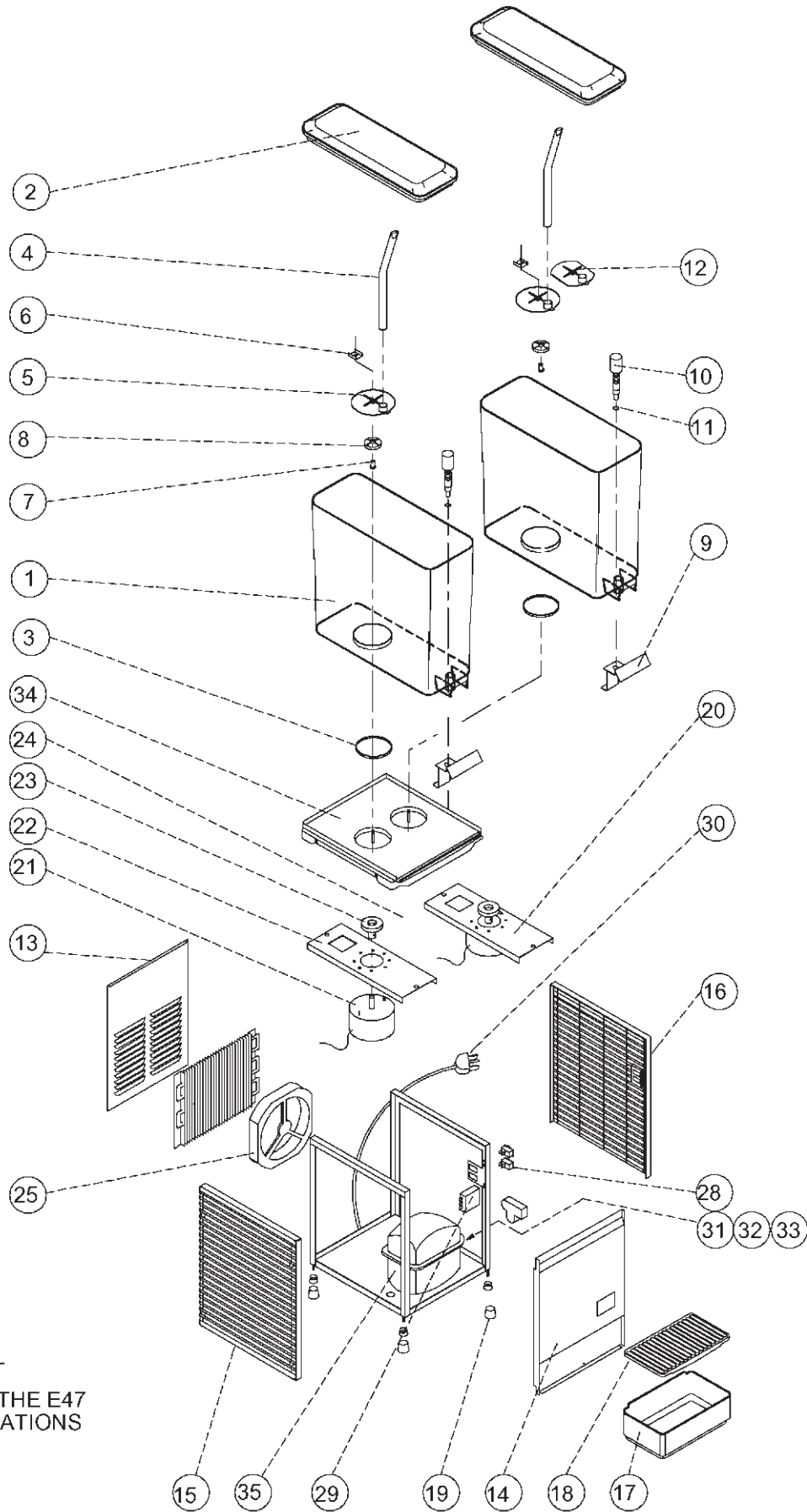

E47 FAN ASSEMBLY

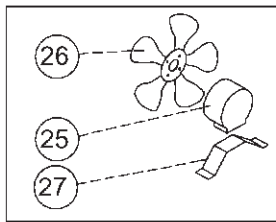

STANDARD E27 SHOWN

SOME COMPONENTS FOR THE E47
MAY BE IN DIFFERENT LOCATIONS
THAN ILLUSTRATED

Parts List Mini Models (E27/9 or E47/9)

ITEM #	DESCRIPTION	E27 3/4	E275 3/4	E276 3/4	E47 3/4	E475 3/4	E476 3/4
BOWL ASSEMBLY PARTS							
1	1.8 GALLON BOWL (7 LITER)	1994	1994	1994	1994	1994	1994
	2.4 GALLON BOWL (9 LITER)	2802	2802	2802	2802	2802	2802
2	BOWL COVER (SINGLE WALL)	1996	1996	1996	1996	1996	1996
	BOWL COVER (DOUBLE WALL)	2999	2999	2999	2999	2999	2999
3	BOWL GASKET	2010	2010	2010	2010	2010	2010
4	SPRAY TUBE (FOR 7 LITER BOWL)	2011	2011	2011	2011	2011	2011
	SPRAY TUBE (FOR 9 LITER BOWL)	2914	2914	2914	2914	2914	2914
5	PUMP COVER	3629	3629	3629	3629	3629	3629
6	WASHER (LOCK DOWN S.S.)	2012	2012	2012	2012	2012	2012
7	BEARING SLEEVE S.S.	3220	3220	3220	3220	3220	3220
8	IMPELLER, MAGNETIC, MOLDED	3629	3629	3629	3629	3629	3629
9	HANDLE (CUP ACTIVATED)	2266	2266	2266	2266	2266	2266
	HANDLE (NON CUP CONTACT)	2484	2484	2484	2484	2484	2484
10	VALVE WITH O-RING	1010A	1010A	1010A	1010A	1010A	1010A
	VALVE WITHOUT O-RING	1010	1010	1010	1010	1010	1010
11	O-RING (VALVE)	1012	1012	1012	1012	1012	1012
12	AGITATOR COVER	2911	2911	2911	2911	2911	2911
CHASSIS CABINERY							
13	BACK PANEL	2337	2791	2337	2647	2647	2647
14	FRONT PANEL	2274	2274	2274	2649	2649	2649
15	LEFT SIDE PANEL -3	2261	2261	2261	2261	2261	2261
	LEFT SIDE PANEL -4	2270	2270	2270	2270	2270	2270
16	RIGHT SIDE PANEL -3	3401	3401	3401	2264	2264	2264
	RIGHT SIDE PANEL -4	3398	3398	3398	2269	2269	2269
17	DRIP PAN -3	3330	3330	3330	3330	3330	3330
	DRIP PAN -4	2231	2231	2231	2660	2660	2660
18	DRIP PAN COVER -3	3335	3335	3335	3335	3335	3335
	DRIP PAN COVER -4	2232	2232	2231	2682	2682	2682
19	TIP LEG (4)	1822	1822	1822	1822	1822	1822
ELECTRICAL COMPONENTS							
(BOTH -3 & -4 UNITS)		(115-60)	(230-50)	(230-60)	(115-60)	(230-50)	(230-60)
		E27	E275	E276	E47	E475	E476
20	PUMP MTR & DRIVE ASSY	2068	2069	3294	2068	2069	3294
21	PUMP MOTOR-ONLY	1068	1122	3217	1068	1122	3217
22	PUMP MOTOR BRACKET	1327	1327	1327	1327	1327	1327
23	DRIVE MAGNET ASSEMBLY	2049	2049	2049	2049	2049	2049
24	SET SCREWS FOR MAGNET ASSM. (set of 6)	0065	0065	0065	0065	0065	0065
25	FAN MOTOR-ONLY	3338	2089	2089	1336	1584	1584
26	FAN BLADE	-	2036	2036	1459	1459	1459
27	FAN MOTOR BRACKET	-	1667	1667	1338	1338	1338
28	ON / OFF SWITCH	3373	3373	3373	2302	2302	2302
29	TEMPERATURE CONTROL	1059	1059	1059	1059	1059	1059
30	SERVICE CORD	1072	1148	1148	1072	1148	1148
31	COMPRESSOR OVERLOAD	3301	2441	3305	1179	3309	2994
32	COMPRESSOR RELAY	2436	3308	3306	3298	3299	2433
33	STARTING CAPACITOR	-	-	-	-	-	-
34	TOP TRAY ASSEMBLY	5581	2466	2466	2678	2678	2678
35	COMPRESSOR 134A	3251	3247	3246	3245	3250	3292

Exploded View and Parts List HD15 - Heated Models

No.	Description	Part#
1	BOWL COVER, SINGLE WALL	1116
2	SPRAY TUBE 3 GALLON	1092
	SPRAY TUBE 5 GALLON	1261
3	WASHER, LOCK DOWN	1734
4	PUMP COVER, SPRAY	3312
	PUMP COVER, AGITATE	3130
5	IMPELLER, MAGNETIC, MOLDED	3587
6	VALVE	2975
	VALVE, WHIPPER	2977
7	O-RING, VALVE	1012
8	BEARING SLEEVE	3220
9	BOWL, 5 GAL. POLYSULPHONE	1288P
	BOWL, 3 GAL. POLYSULPHONE	1090P
10	SPRING	1929
11	HANDLE (CUP ACTIVATED)	2266
	HANDLE (NON CUP CONTACT)	2484
	HANDLE, WHIPPER	2955
12	GASKET, BOWL	1013
13	TRAY, HEATING ASSEMBLY	3288
14	PANEL, 3-HOLE PLASTIC	3399
	PANEL, 2-HOLE PLASTIC (WHD15L)	3398
15	PANEL, FRONT	2640
	PANEL, FRONT WHIPPER	2845
16	COVER, DRIP PAN	2232
17	PAN, DRIP	2231
18	LEG, 1"	1821
	LEG, 3"	2543
19	SWITCH, ROCKER	3373
20	SERVICE CORD, 115V	1072
	SERVICE CORD, 230V	1148
21	PANEL, LEFT	2270
22	PANEL, BACK	2312
23	BLADE, FAN	3037
24	PUMP MOTOR, 115V	1351
	PUMP MOTOR, WHIPPER 115V	1655
	PUMP MOTOR, 230V	1594
	PUMP MOTOR, WHIPPER 230V	3287
25	BRACKET, PUMP MOTOR	1327
26	TERMINAL BOARD	2057
27	CONTROL, THERMOSTAT 120V	2985
	CONTROL, THERMOSTAT 220V	2969
	CONTROL, THERMOSTAT WHD15L	3427
28	HEATER, 120V	3013
	HEATER, 220V	3059
29	CLIP, HEATER	3012
30	CONTROL, THERMOSTAT BACKUP	2986
31	MAGNET, DRIVE ASSY	1733

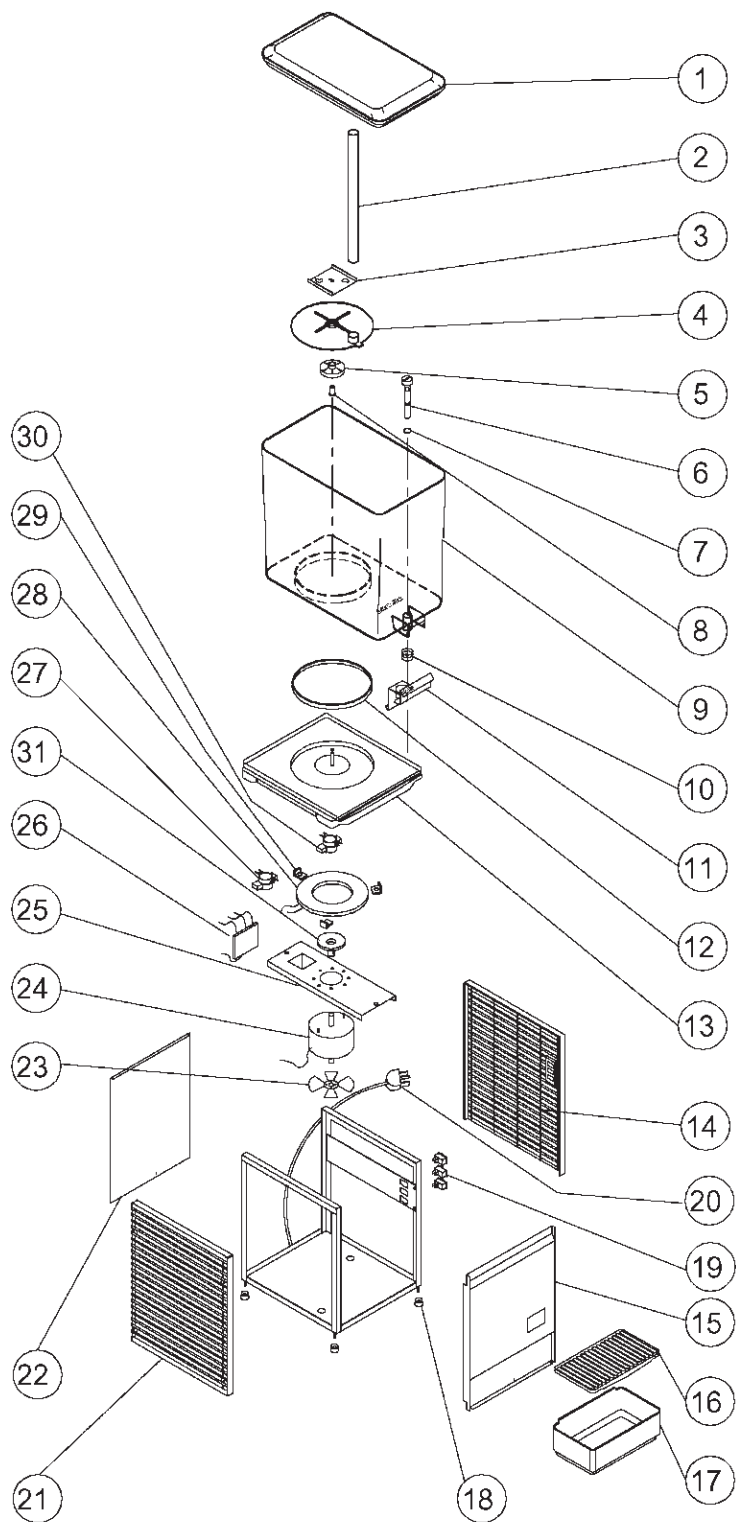

* SEE PAGE 16 FOR ALL OTHER WHIPPER PARTS

Parts not shown	
ARMS, STANDARD	2961
ARMS, WHIPPER	2962
FEET	1822

Super Bowl (D112) Bowl Assembly Parts

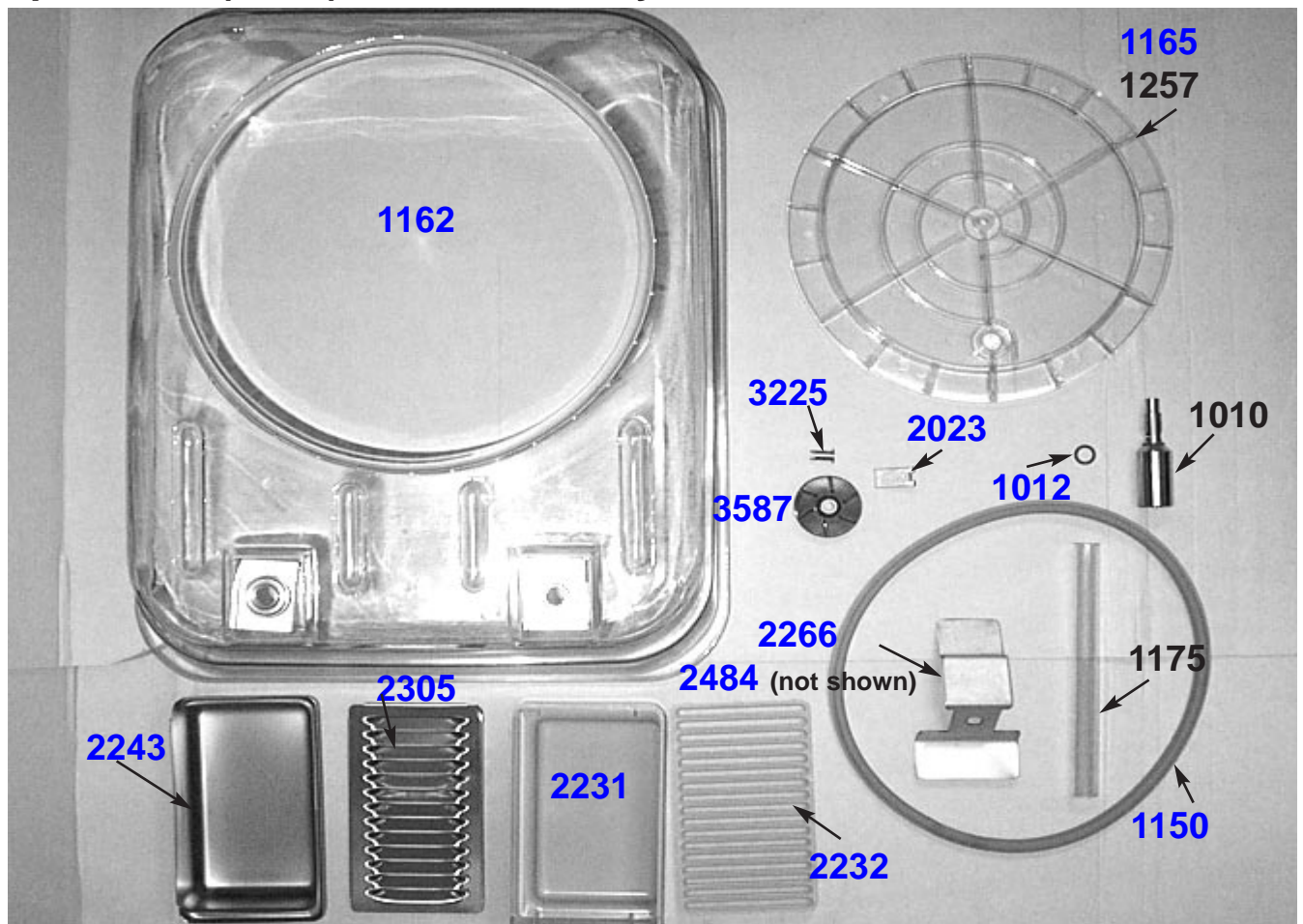

Part #	Description	Models Used On
1010	Dispense Valve	All Standard (non- whip)
1012	O-ring for Dispense Valve	All
1150	Bowl Gasket	D112
1155	Super Bowl Lid	D112
1162	Super Bowl (12 gal)	D112
1165	Super Bowl Pump Cover (use with spray tube)	D112
1175	Super Bowl Spray Tube	D112
1257	Agitator (use in place of pump cover and spray tube for iced tea, orange juice, and viscous products)	D112
2023	Lock Washer	D112
2231	Plastic Drip Tray	D15, D25, D35, E27, E47, D112, HD15, and all WD models
2232	Plastic Drip Tray Grid	D15, D25, D35, E27, E47, D112, HD15, and all WD models
2243	Stainless Steel Drip Tray	D15, D25, D35, E27, E47, D112, HD15, and all WD models
2266	Dispense Valve Handle	All Standard (non- whip)
2305	Stainless Steel Drip Tray Grid	D15, D25, D35, E27, E47, D112, HD15, and all WD models
2484	Handle, Non Cup Contact	All Standard (non- whip)
3225	Bearing Sleeve	All
3587	Impeller (black)	All D, HD, and WD models

Wiring Diagrams Standard Models 115V & 220V

Single Bowl D15/D155/D156

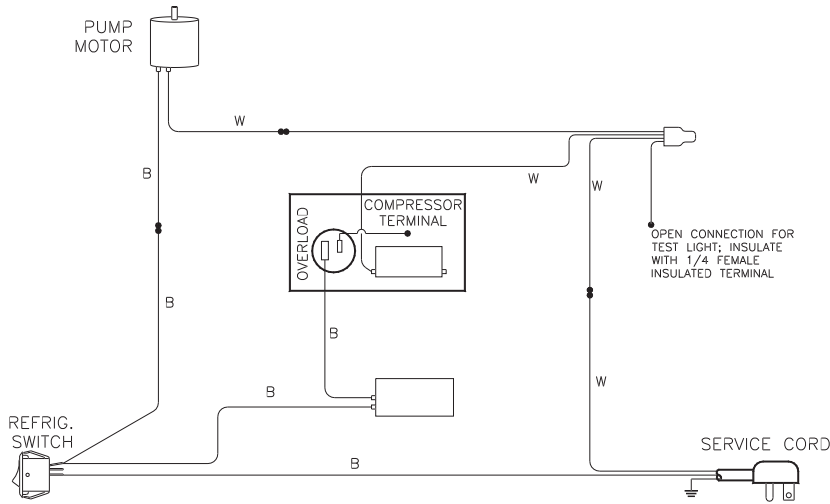

Double Bowl D25/D255/D256

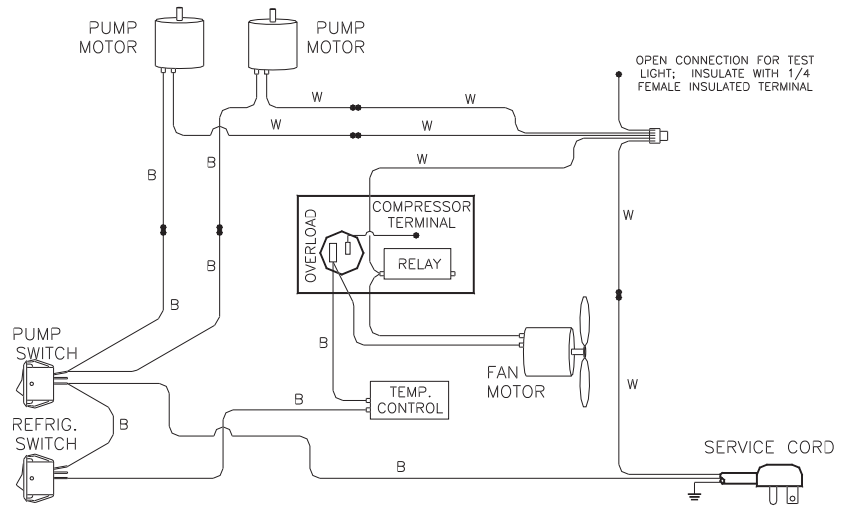

Triple Bowl D35/D355/D356

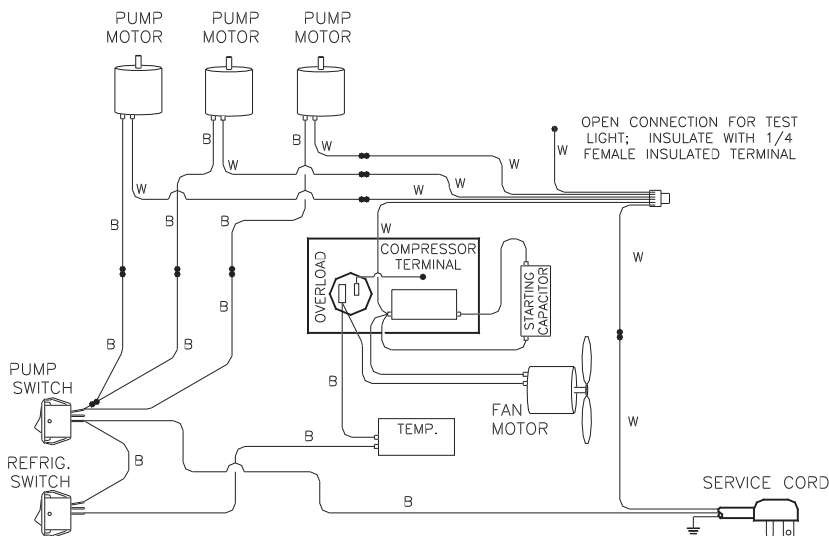

Wiring Diagrams for Mini Models (115V & 220V)

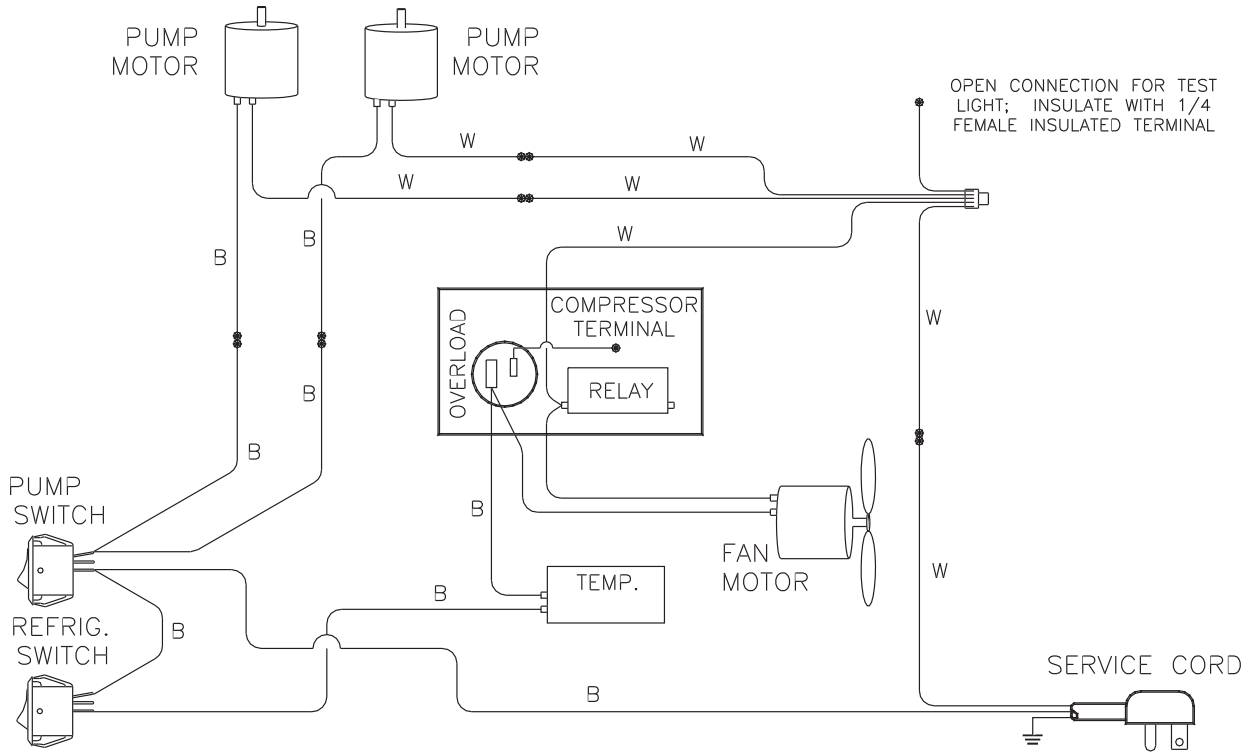

**Models E27, E275, and E276
or E29, E295, and E296**

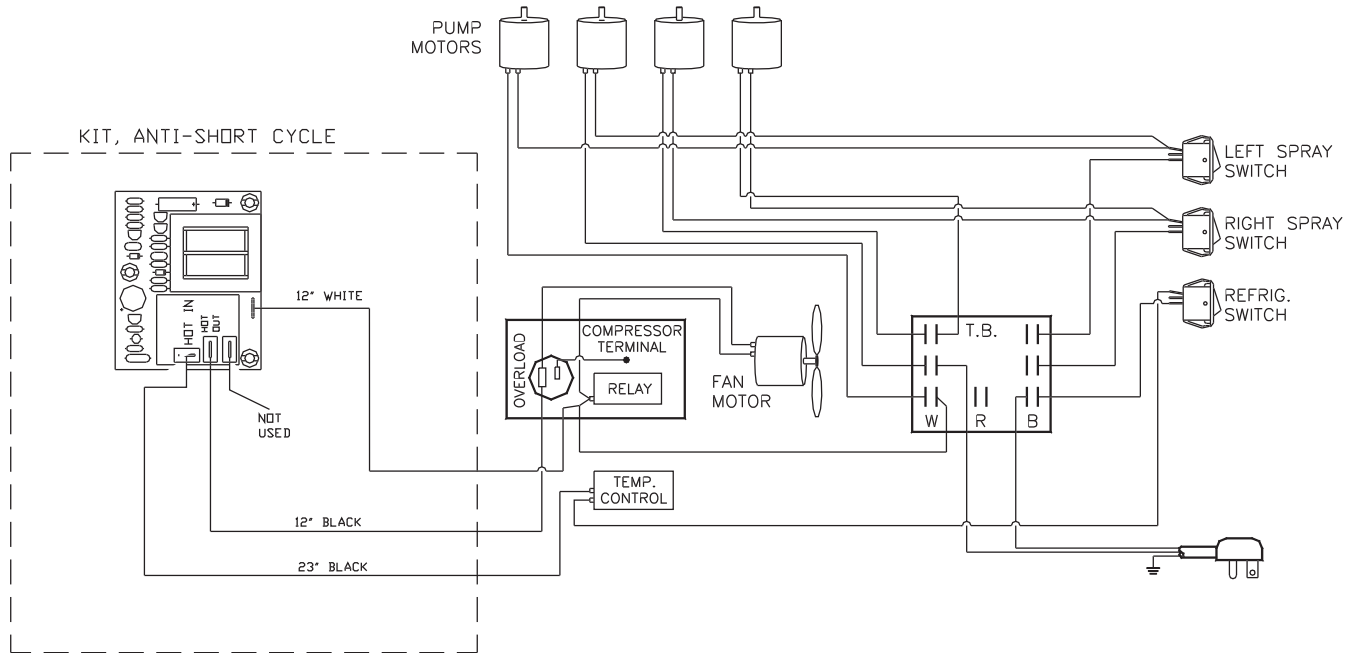

**Models E47, E475, and E476
or E49, E495, and E496**

Wiring Diagrams Whipper Models

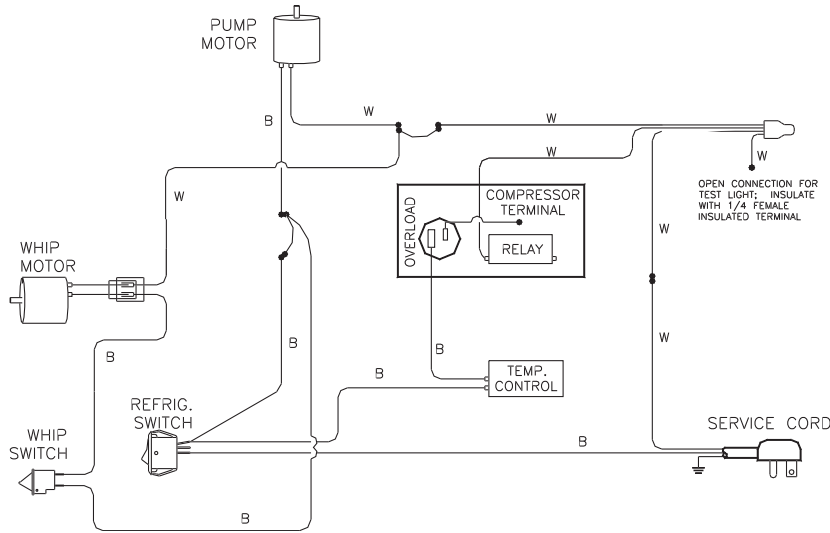

**Single Bowl
WD15**

**Double Bowl
2WD25
1WD25-4**

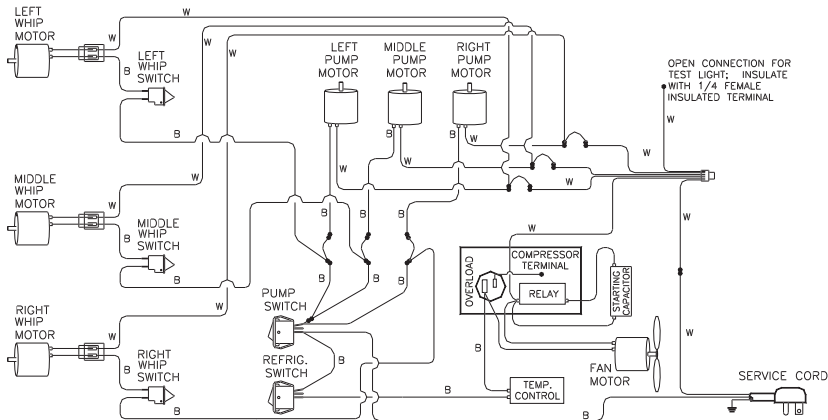
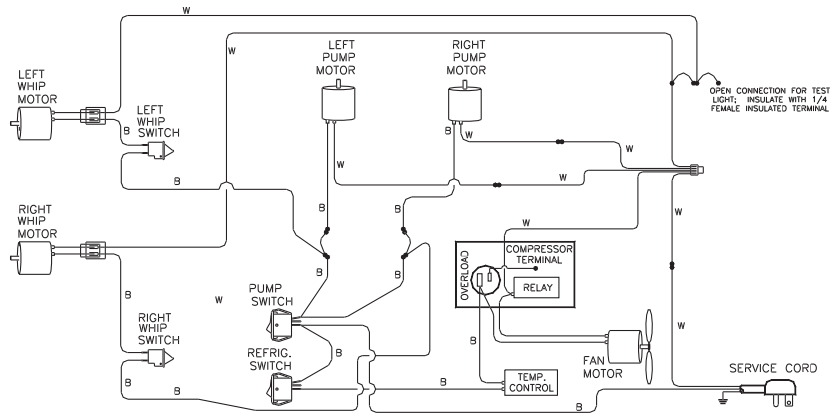

**Triple Bowl
3WD35
2WD35-4
1WD35-4**

Wiring Diagram for Heated Models (HD15 & WHD15) 115V/60Hz and 230V/50Hz

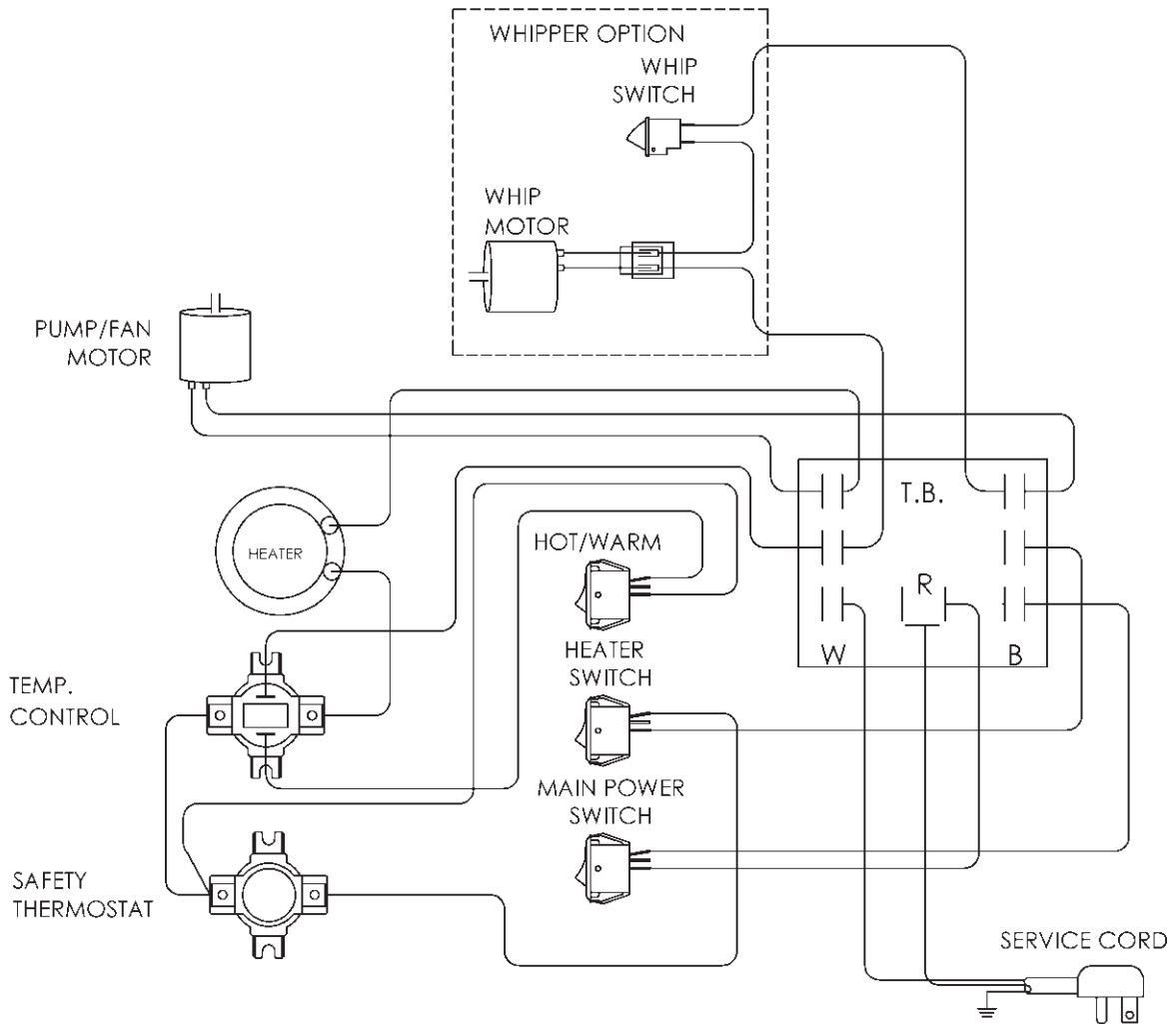

Refrigeration Schematic

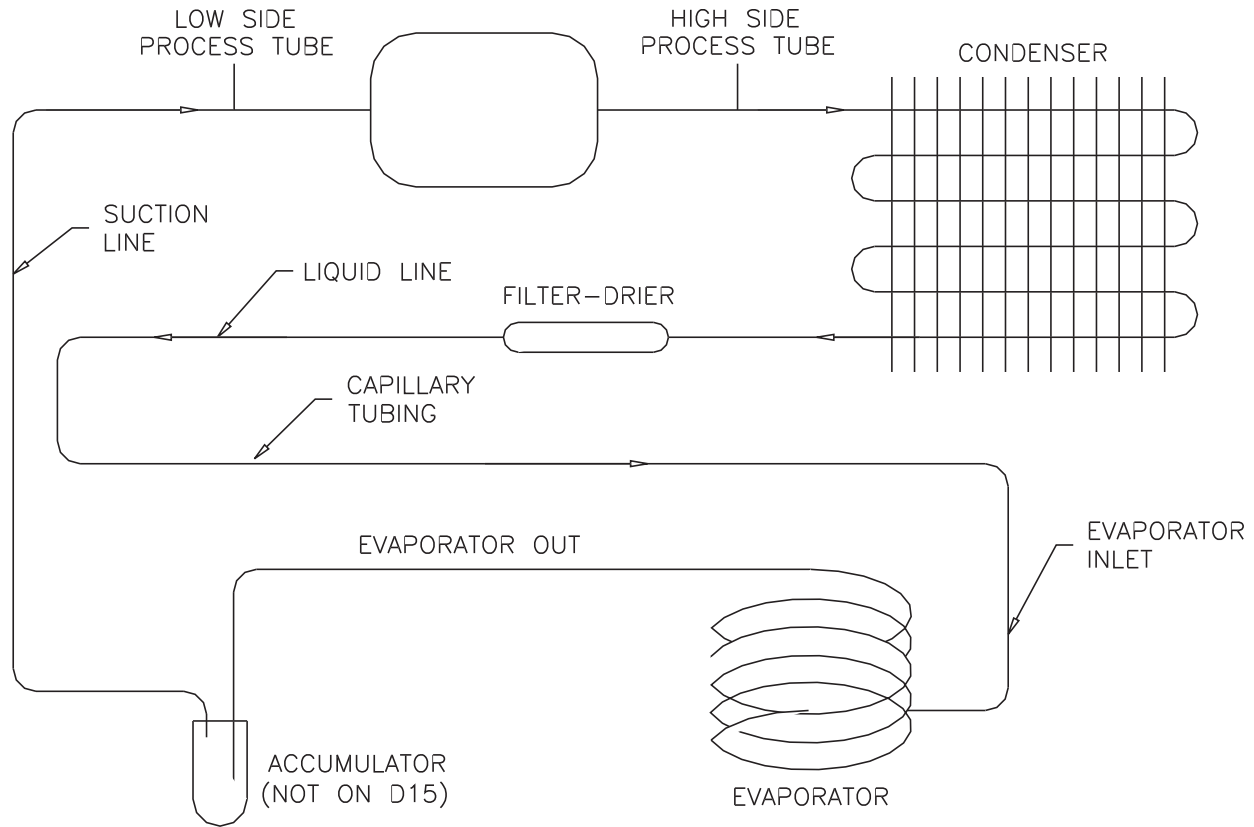

CAP TUBE SPECIFICATIONS				
Model	OD	ID	Length	GCS Part #
D15	.073	.031	76"	2308
D25	.087	.036	60"	1324
D25	.088	.036	52"	2968
D35	.093	.042	66"	3361
D112	.097	.042	97"	1199
WD35	.093	.042	66"	3361

REFRIGERANT CHARGE FOR CRATHCO DISPENSERS			
1 oz = 28.34952 grams			
	grams	ounces	
D15	89	3.1	1/6 hp
D155/6	97	3.4	
D25	190	6.7	1/5 hp
D255/6	190	6.7	
D35/D355	197	6.9	1/3 hp
E17	50	1.8	
E27	120	4.2	1/6 hp
E275/6	89	3.1	
E47	161	5.7	1/5 hp
E475/6	161	5.7	
D112	196	6.9	1/4 hp
D1125	196	6.9	



GRINDMASTER™

C O R P O R A T I O N

Grindmaster® Coffee Grinders and Brewers • Espresso® Espresso Machines • Crathco® Hot Beverage Dispensers
Crathco® Cold and Frozen Beverage Dispensers • American MetalWare® Coffee and Tea Systems
Tel (502) 425-4776 • Fax (502) 425-4664 • 1-800-695-4500
P.O. Box 35020 • Louisville, KY 40232 • USA
www.grindmaster.com • email: info@grindmaster.com