



HIGH TEMPERATURE HEAT RECOVERY UNDERCOUNTER DISHWASHER / GLASSWASHER

181-VL



CMA MODEL: 181-VL



Stainless Steel Pedestal
24"W X 25-3/8"D X 15-1/4"H

FEATURES

- Soft Start feature lowers noise and reduces chance of breakage
- Reduces water vapor for under bar application
- Heat Recovery System promotes faster drying of wares
- Large 11-1/4" height clearance accommodates larger wares.
- Top mounted controls are easy to read and simple to operate.
- 304 Stainless Steel construction
- 20 racks per hour
- .73 gallon of water per cycle or rack
- Safe-T-Temp booster heater for a 70°F rise
- 180°F fresh water final rinse
- Detergent and rinse aid chemical pumps
- 180 seconds cycle
- Removable Stainless Steel pump protection screen for easy cleaning
- Reduced energy costs-uses only cold water supply
- Raised door height makes it easier to remove racks
- 1.0 HP corrosion resistant pump
- Stainless Steel upper and lower wash and rinse arms
- Automatic fill function
- 6" Stainless Steel Legs
- Built in Delime switch.

AVAILABLE OPTIONS

- 4" Stainless Steel Legs





181-VL
High Temperature
Heat Recovery Undercounter
Dishwasher / Glasswasher

WARNINGS:

- Plumbing connections must be made by a qualified service company who will comply with all available Federal, State, and Local Health, Plumbing and Safety codes.
- CMA recommends utilizing a water softening system to maintain water hardness measurements of 3.5 gpg (grains per gallon) or less. This will assure maximum results and optimum operation of the dishwasher.

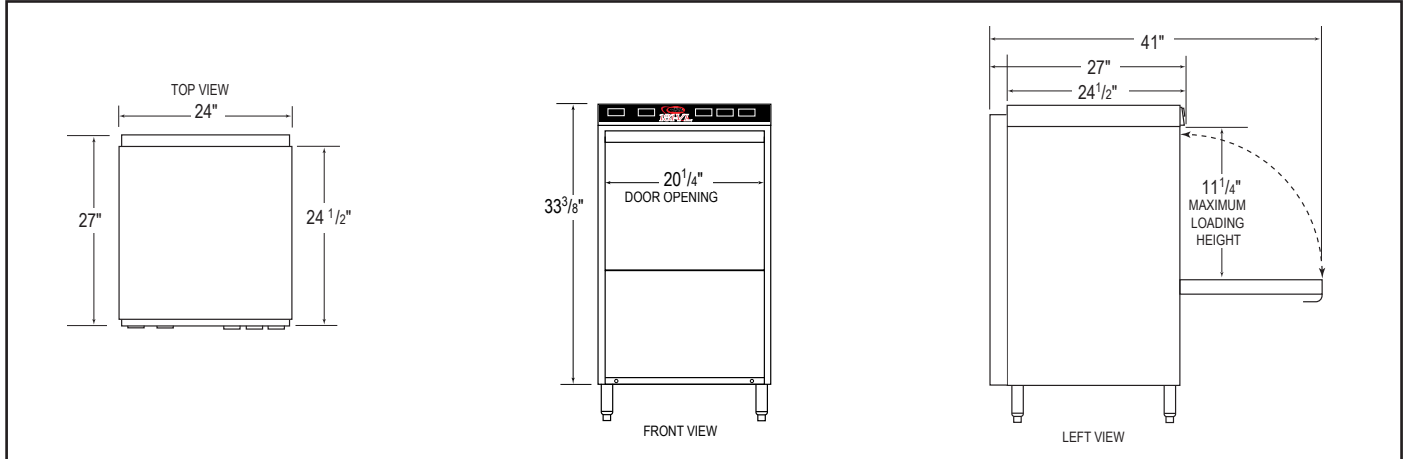

Specifications:

MODEL CMA 181-VL	USA	(Metric)	CMA 181-VL	USA	(Metric)
WATER CONSUMPTION			FRAME DIMENSIONS		
PER RACK	.73 GAL.	(2.76 L)	DEPTH	27"	(68.6 CM)
PER HOUR	14.6 GAL.	(55.3 L)	WIDTH	24"	(60.96 CM)
OPERATING CYCLE			HEIGHT	33-3/8"	(84.77 CM)
WASH TIME-SEC	96	96	MAX CLEARANCE FOR WARES	11-1/4"	(28.6 CM)
RINSE TIME-SEC	14	14	WASH PUMP MOTOR 1 HP 1 HP		
DWELL TIME-SEC	3	3	ELECTRICAL RATING		
VENT FAN-SEC	65	65	208 VOLTS 240 VOLTS		
TOTAL CYCLE TIME-SEC	178	178	1 PH-60 Hz 1 PH-60 Hz		
OPERATING CAPACITY			TOTAL AMPS 33.0 AMPS 36.0 AMPS		
RACKS PER HOUR	20	20	BOOSTER HEATER KW 5.3 KW 7.1 KW		
WASH TANK CAPACITY 2.5 GAL. (9.46 L)			THIS SYSTEM REQUIRES THREE POWER WIRES WHICH INCLUDES A CURRENT CARRYING NEUTRAL. AN ADDITIONAL FOURTH WIRE MUST BE PROVIDED FOR MACHINE GROUND. NO GFI BREAKER.		
PUMP CAPACITY 38 GPM (144 LPM)					
WATER REQUIREMENTS			APPROXIMATE SHIPPING WEIGHT 272# (123 KG)		
COLD WATER TEMP	41-65°F	(5-18°C)	SHIPPING DIMENSIONS PALLET & BOX 29" X 28" X 41"		
WATER INLET	1/2"	(1.27 CM)			
DRAIN CONNECTION	1"	(2.54 CM)			
RINSE PRESSURE SET	20 ±5PSI	1.41 KG/CM ²			
CYCLE TEMPERATURES					
WASH-°F	150° F-160° F	(65.5°C/71°C)			
RINSE-°F	180° F-195° F	(82°C/90°C)			

Summary Specifications: CMA 181-VL

The CMA 181-VL undercounter dishwasher with heat recovery technology reduces hot water vapor at end of cycle, provides hot water (1800F) sanitizing through the use of a built-in booster heater. 180°F final rinse safety system ensures proper temperatures in the final rinse by holding wash cycle in run mode until 180°F rinse temperature is detected. The unit comes standard with upper and lower stainless steel wash and final rinse arms, digital LED temperature gauges and easy to operate controls. The CMA 181-VL is constructed entirely of stainless steel. Uses standard 19-3/4"X19-3/4" glassracks with a 11-1/4" door clearance. This dishwasher only requires a cold water hookup.

Advisory: CMA does NOT endorse "Tankless On-Demand" water heaters for use on CMA Dishmachine products. CMA DOES endorse, and highly recommends, the standard "tank" style water heaters, sized properly to handle each particular facility with their water heating requirements.



CMA Dishmachines 12700 Knott Street, Garden Grove, CA 92841 • 800-854-6417 • 714-898-8781 • Fax: 714-895-2141 • www.cmadishmachines.com

CMA reserves the right to modify specifications or discontinue models without prior notification.

© 7-2022 CMA, Inc.

an Ali Group Company



The Spirit of Excellence