

FRYERS**VULCAN****1GR65M
FREE STANDING GAS FRYER****SPECIFICATIONS**

65 - 70 lbs. capacity free standing gas fryer, Vulcan-Hart Model No. 1GR65M. Stainless steel cabinet. Set of four 6" adjustable casters (2 locking). Stainless steel fry tank with five heat exchanger tubes and a "V" shaped cold zone. 1/4" full port ball type drain valve. Twin fry baskets with plastic coated handles. 150,000 BTU/hr. input. Millivolt (M) control system. Tank brush, stainless steel crumb scoop and clean-out rod.

CSA design certified. NSF listed.

SPECIFY TYPE OF GAS WHEN ORDERING

- Natural Gas.
 Propane Gas.

SPECIFY ALTITUDE

- Natural Gas for above 2000 ft.
 Propane Gas for above 3500 ft.

1GR65M: Behind the door millivolt thermostat control adjusts from 200° to 400°F.

STANDARD FEATURES

- Stainless steel fry tank, 65 - 70 lb. capacity. Includes limited 10 year tank warranty.
- 1/4" full port ball type drain valve.
- Stainless steel cabinet.
- Set of four 6" adjustable casters (2 locking).
- Twin fry baskets with plastic coated handles.
- 150,000 BTU/hr. input.
- Five heat exchanger tubes positioned for easy cleaning.
- Hi-limit shut-off.
- Combination gas shut-off valve and pilot safety system.
- Tank brush, stainless steel crumb scoop and clean-out rod.
- One year limited parts and labor warranty.

ACCESSORIES

- FRYMATE-VX15 add-on frymate.
- Stainless steel tank cover – doubles as a work surface top.
- Connecting Kit(s) – Connects two fryers together (brackets, grease strip and hardware included).
- Single large basket – 18 3/4" w x 13 1/4" d x 5 1/2" h.
- Set of twin baskets – 9 1/4" w x 13 1/4" d x 6" h.
- 3/4" Flexible gas hose with quick disconnect.
- 10" high stainless steel removable splash guard.

OPTIONS

- Second year extended limited parts and labor warranty.

VULCAN

a division of ITW Food Equipment Group LLC

P.O. Box 696 ■ Louisville, KY 40201 ■ Toll-free: 1-800-814-2028 ■ Local: 502-778-2791 ■ Quote & Order Fax: 1-800-444-0602



1GR65M FREE STANDING GAS FRYER

INSTALLATION INSTRUCTIONS

1. A combination valve with pressure regulator is provided with this unit.
 - Natural Gas
Operating pressure – 4.0" W.C.
Recommended supply pressure 7-9" W.C.
Not to exceed 14" W.C. (1/2 PSI)
 - Propane Gas
Operating pressure – 10.0" W.C.
Recommended supply pressure 11-12" W.C.
Not to exceed 14" W.C. (1/2 PSI)
2. An adequate ventilation system is required for Commercial Cooking Equipment. Information may be obtained by writing to the National Fire Protection Association, Batterymarch Park, Quincy, MA 02269. When writing refer to NFPA No. 96.

3. All models require a 6" (152 mm) clearance at both sides and rear adjacent to combustible construction. All models require a 16" (407 mm) minimum clearance to adjacent open top burner units.
4. This appliance is manufactured for commercial installation only and is not intended for home use.

SERVICE CONNECTIONS:

Ⓟ 1/2" (13 mm) ID and 3/4" (19 mm) OD rear gas connection.

NOTE: In line with its policy to continually improve its product, Vulcan reserves the right to change materials and specifications without notice.

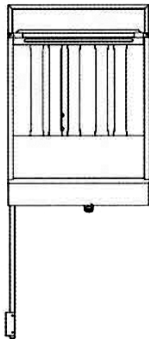

1GR65M
Top

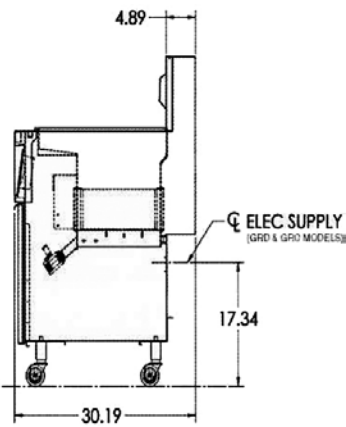

1GR65
Right Side

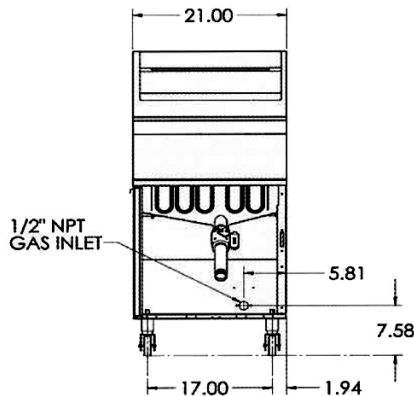

1GR65M
Front

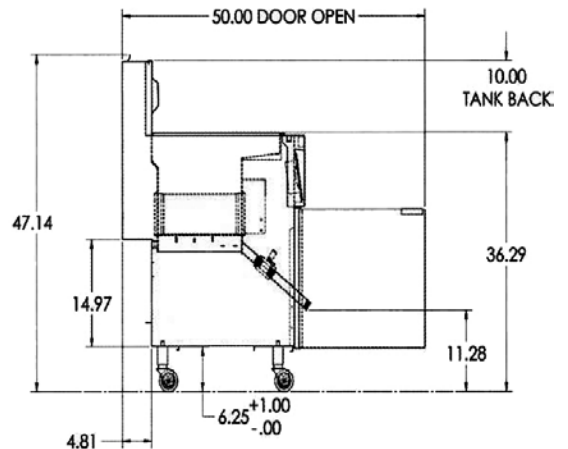

1GR65
Left Side

MODEL	Width	Depth	Overall Height	Working Height	Tank Size	BTU/hr.	Fry Comp. Capacity	Approx. Shipping Weight
1GR65M	21"	30 ¹ / ₈ "	47 ¹ / ₈ "	36 ¹ / ₄ "	19 ¹ / ₂ " x 14"	150,000	65 - 70 lbs.	275 lbs.

This appliance is manufactured for commercial use only and is not intended for home use.



a division of ITW Food Equipment Group LLC

P.O. Box 696 ■ Louisville, KY 40201 ■ Toll-free: 1-800-814-2028 ■ Local: 502-778-2791 ■ Quote & Order Fax: 1-800-444-0602