



Outperform every day.™

ENGLISH

Operator's Manual



TOMATO PRO™
ECONO PRO™
TOMATO KING™



Thank you for purchasing this Vollrath Food Processing Equipment. Before operating the equipment, read and familiarize yourself with the following operating and safety instructions. **SAVE THESE INSTRUCTIONS FOR FUTURE REFERENCE.** Save the original box and packaging. Use this packaging to ship the equipment if repairs are needed.

SAFETY PRECAUTIONS

To ensure safe operation, read the following statements and understand their meaning. This manual contains safety precautions which are explained below. Please read carefully.

WARNING

Warning is used to indicate the presence of a hazard that can cause severe personal injury, death, or substantial property damage if the warning is ignored.

CAUTION

Caution is used to indicate the presence of a hazard that will or can cause minor personal injury or property damage if the caution is ignored.

NOTE

Note is used to notify people of installation, operation, or maintenance information that is important but not hazard-related.

For Your Safety!

These precautions should be followed at all times. Failure to follow these precautions could result in injury to yourself and others or damage the equipment.

To reduce risk of injury or damage to the equipment:

- Check equipment before each use to insure the equipment is clean.
- Check for broken, nicked or dull blades and if found, replace blade assembly.
- Check to insure that the pusher head sits down completely on the rubber bumpers. The suction cups on each rear leg will hold the equipment securely to smooth surfaces.
- If necessary, lubricate guide rods using a light coating of mineral oil, Petro Gel, or food grade lubricant. **DO NOT USE COOKING OIL AS IT WILL BECOME STICKY AND MAY PERMANENTLY DAMAGE THE PUSHER HEAD BEARINGS**

FUNCTION AND PURPOSE

Intended for slicing of tomatoes.

OPERATION

	 WARNING
	Sharp Blade Hazard. Blades are sharp and can cause cuts and amputation.
To avoid injury from sharp blades, handle with caution. Only trained personal should operate equipment or preform maintenance.	

Prior to first use, it is important to clean the equipment. Wash new blades with warm soapy water and rinse thoroughly to remove the thin protective oil film.

1. Before each use, always check for proper blade tightness by strumming the dull side of the blade to identify a uniform vibration. If loose or broken blades are found, blades must be serviced.
2. Place the slicer on a table or counter. Position the Tomato Pro Positive Stop Pivot Arm over a table edge or sink edge to hold the equipment securely.
3. The equipment should always be used to slice tomatoes, mushrooms, strawberries, etc. Hard foods such as onions, lemons, etc. will cause blades to break.
4. Use the Tomato King Scooper to remove the stem scar from the tomato. For best results, the tomatoes should be clean and wet before slicing them in the tomato equipment. Spray plastic platform and blades with water to reduce friction.
5. Place the tomato (top down) on the platform of the slicer against the pusher head and blade, scoring the tomato slightly. With a quick push of the pusher head, push the tomato through the blades catching slices at the rear of the blade assembly with your other hand.
6. Repeat this process until you have prepared enough tomatoes for your daily needs.
7. If the equipment no longer slices tomatoes cleanly or without damage to the tomatoes, the blades could be dull and be in need of replacement. See the **REPLACING BLADE ASSEMBLY** section of this manual for additional information.
8. The pusher head should slide smoothly through the blades without interference with the blades. If an adjustment needs to be made, see the **ADJUSTMENT** section of this manual for more information.
9. Clean and lubricate your equipment immediately after each use. See the **CLEANING** section for more information.

CLEANING

	 WARNING
	Sharp Blade Hazard. Blades are sharp and can cause cuts and amputation.
To avoid injury from sharp blades, handle with caution. Only trained personal should operate equipment or preform maintenance.	

To maintain the appearance and increase the service life, clean your daily.

1. Place Pusher Head Assembly in its most "open" position by retracting the handle.
2. Rinse or spray off equipment thoroughly with HOT water. You may want to immerse the complete equipment in warm soapy water first. Use caution when handling the equipment - blades are sharp!
3. Do not wipe across blades or use scrub pads on this equipment. Wiping across the sharp edge of the blade can cause injury and will dull the blades.
4. Do not put this equipment in a dishwasher or dish machine with soaps, detergents, or other alkaline chemicals that can harm the equipment.
5. After cleaning, let the equipment air dry.
6. Lubricate sliding parts with mineral oil or Petro Gel after each use. Do not use cooking oil as it will become sticky and may permanently damage the equipment.

NOTE:

Food acids will make blades dull and corrode the metal. Always clean this food preparation equipment immediately after every use.

PREVENTATIVE MAINTENANCE

1. Clean the equipment after every use.
2. Keep proper blade tension.
3. Use for intended purposes only.
4. Change the blades regularly - based on usage.

REPLACING BLADE ASSEMBLY

	WARNING
	<p>Sharp Blade Hazard. Blades are sharp and can cause cuts and amputation.</p>
<p>To avoid injury from sharp blades, handle with caution. Only trained personal should operate equipment or preform maintenance.</p>	

We suggest you change the complete assembly. Never mix old and new blades in the same assembly as this may lead to excessive blade breakage.

Wash new blades with warm, soapy water and rinse thoroughly to remove the thin protective oil film. Keep the sharp edge away from you when handling blades.

1. Allow yourself ample room to work on a flat, dry surface. Familiarize yourself with the parts diagram for your equipment. Blade assemblies consist of blades, blade blocks, blade block pins, rubber seals, and screws.
2. When changing blade assemblies on the Tomato King, close the pusher head so that the pusher head fingers are through the blades resting against the pin stop.
3. When changing blade assemblies on the Tomato Pro and Econo Pro equipment, pull the pusher head assembly back away from the blades so it is against the back stop.
4. To remove blade assemblies, use the proper tool to remove the four blade block screws (2 at each end). Retain the rubber seals that are mounted on the screws between the blade blocks and the casting.
5. Dispose of used blades and blade assemblies properly.

ADJUSTMENTS

1. Examine the pusher head fingers. If they are nicked or burred, smooth the rough edges with a small flat file. The spaces between the fingers must be uniform. Straighten any bent fingers.
2. Center the new blade assembly between bridge casting posts with the sharp side facing the pusher head. Replace screws and rubber seals. Be certain that the bottom blade fits between the two bottom-most pusher head fingers.
3. Check the clearance between the pusher head fingers and blades. Make sure they do not rest on or touch the blades at any point when you move the head through its full travel. If there is contact, adjustments must be made. Pusher head fingers must never contact blades.

To adjust Pusher Head Fingers between blades:

1. Carefully insert a screwdriver (B) between the slots in the Pusher Head Assembly (A). Gently tap on the screwdriver (B)(up or down) to alter the location of the Pusher Head Fingers so the slide effortlessly through the blades. See Figure 1.

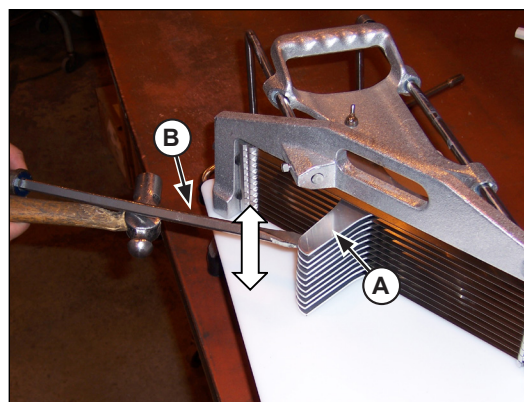

Figure 1. Pusher Head Adjustment Between the Blades.

2. It may also be necessary to adjust the Pusher Head Assembly (A) from the back side of the equipment, as well. If needed, carefully insert a screwdriver (B) between the slots in the Pusher Head Assembly. Gently tap on the screwdriver (B) (up or down) to alter the location of the Pusher Head Fingers so they slide effortlessly through the blades. See Figure 2.

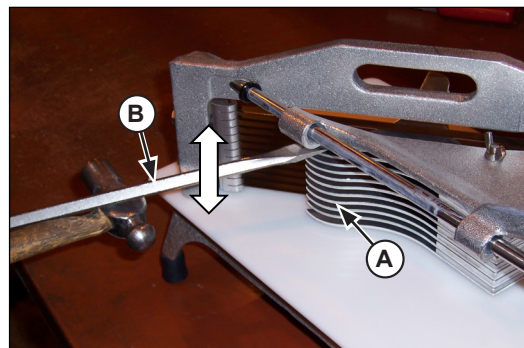

Figure 2. Pusher Head Adjustment Between the Blades.

Adjust the Pusher Head Assembly through the Blades:

1. Momentarily loosen set screws to the guide rods to adjust the location of the Pusher Head Assembly by pushing / pulling on the guide rod. Once the Pusher Head Assembly is properly located, tighten the set screws. See Figure 3.



Figure 3. Pusher Head Adjustment Through the Blades.

Tightening the blades:

Blades must be tightened in alternating sequence

1. Keep blade assembly centered between casting end-posts with a gap of air space between the blade block and post.
2. Tighten screws one-half turn at a time in the following order:
 - A. Top Right - 1/2 Turn
 - B. Bottom Left - 1/2 Turn
 - C. Bottom Right - 1/2 Turn
 - D. Top Left - 1/2 Turn
3. Repeat this sequence until the screws are tight. Check for proper blade tightness by strumming the dull side of the blade to identify a uniform vibration.

TROUBLESHOOTING

If the equipment no longer processes food cleanly or without damage to the food product, the blades could be dull and be in need of replacement. Broken, bent, or nicked blades must be replaced.

Problem	It might be caused by	Course of Action
Broken Blade.	Wrong food used in equipment.	Slice only what is recommended.
	Blade tension not correct - too tight or too loose.	Change blades following instructions.
	Fingers misaligned.	Check blade tension before each use.
	Old and new blades used after blade replacement.	Never mix old and new blades.
	Blades were dull.	Pre-score whenever possible to avoid undue shock and stress to blades.

SERVICE AND REPAIR

Please contact Vollrath Technical Service from the list below.

- VOLLRATH Technical Service • 1-800-628-0832**
- Email: techservicereps@vollrathco.com**

When contacting Vollrath Technical Service, please be ready with the item number, model number (if applicable), serial number, and proof of purchase showing the date the equipment was purchased.

SPARE PARTS LIST - TOMATO PRO & ECONO PRO

LETTER	PART NUMBER	DESCRIPTION
A	NLA	Blade Block Pin (order Blade Assembly)
B	060	Rubber Feet (Old Style)
	303	Rubber Feet, Deep (New Style)
C	0658	Rubber Seal
D	0660	Bolt, Blade Block (New Style) Hex Head 1/4-20 x 1 3/8"
	NLA	Bolt, Blade Block (Old Style) Allen Head 1/4-20 x 1 3/8" (order 0660)
E	0661	Pusher Head Casting (Old Style)
F	0662	3/16" and 3/8" Pusher Head Assembly
	0663**	1/4" Pusher Head Assembly
	379035**	7/32" Pusher Head Assembly
G	0664	Bridge Casting
H	0666L	Guide Rod, Left (Long)
I	0666R	Guide Rod, Right (Short)
J	0667	Base Casting
K	0670	Platform (Tomato Pro with Safety Guard)
	0671	Platform (Tomato Pro w/out Safety Guard)
	0686	Platform (Econo Pro with Safety Guard)
L	0673	Set Screw, Guide Rod
M	0676	Screw, Retaining (Bridge Casting to Base)
N	NLA	Pivot Post, Safety Guard (Old Style)
O	0680	Pivot Stop, Pivot Arm
P	0682	Safety Guard - Tomato Pro (New Style) (Includes guard, screws and nuts to secure in place)
	NLA	Safety Guard - Econo Pro (New Style)
Q	0687	Pusher Head Casting (New Style)
R	0688	End Bumper, Positive Stop
S	2319	Rubber Feet (Econo Pro)
T	305	Rubber Stop
U	356	Wing Nut (New Style)
V	369211	Thumb Screw (Insert from Top with Econo Sfty Gd)
W	519	Acorn Nut - Used with old style pusher head only
X	NLA	Guide Rod (Econo Pro Only)
Y	EC0671	Platform (Econo Pro w/out Safety Guard)
Z	NLA	Safety Guard - Old Style
AA	NLA	Spring, Safety Guard (Old Style)
BB	NLA	Blade, Single - Scalloped
	NLA	Blade, Single
	0648	Blade Assembly, 3/16" (15 Blades) - Scalloped
	0653	Blade Assembly, 3/16" (15 Blades)
	0652	Blade Assembly, 1/4" (11 Blades) - Scalloped
	0654	Blade Assembly, 1/4" (11 Blades)
	0647	Blade Assembly, 3/8" (8 Blades) - Scalloped
	0656	Blade Assembly, 3/8" (8 Blades)
CC	855528	Washer
DD	850089	Aluminum Stop

**NOTE: Old Style (two studs) pusher head assembly is no longer available. The new style (one stud) pusher head assembly must be used with the new style pusher head casting (P/N 0687). NLA = Part no longer available through The Vollrath Company, LLC.

EXPLODED VIEW - TOMATO PRO & ECONO PRO

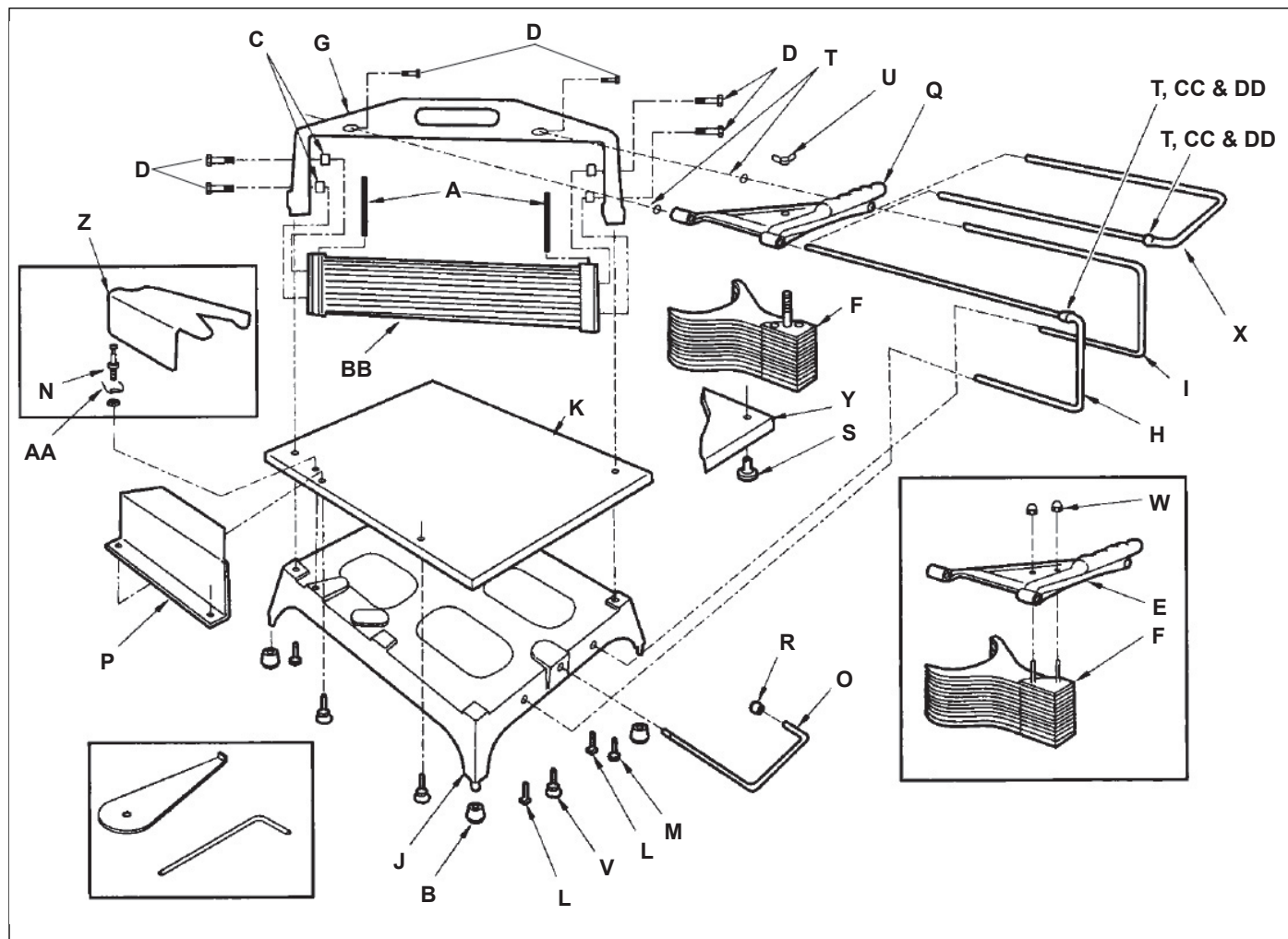

SPARE PARTS LIST - TOMATO KING

LETTER	PART NUMBER	DESCRIPTION
A	NLA	Pusher Head and Handle Assembly (3/16" and 3/8")
	NLA	Pusher Head and Handle Assembly (1/4")
B	NLA	Bridge Casting (Old Style)
	NLA	Bridge Casting (New Style)
C	NLA	Platform
D	NLA	Base Casting
E	060	Rubber Feet (Old Style)
	303	Rubber Feet, Deep (New Style)
F	NLA	Pivot Post, Nut and Washer Assembly
G	NLA	Nylon Disk
H	NLA	Pusher Head Adjustment Screw and Nut
I	NLA	Stop Pin and Bolt
J	071	Screw, Hex Head Stainless, 1/4-2- x 1 1/4"
K	0304	Red Knob
L	NLA	Nipple
M	NLA	Handle Casting (Old Style)
N	NLA	Screw, Allen Head Stainless 1/4-20 x 1 3/4"
O	NLA	Screw, Hex Head Stainless 1/4-20 x 7/8"
P	0658	Rubber Seal
Q	NLA	Blade Block (3/16" and 3/8")
	NLA	Blade Block (1/4")
R	NLA	Blade Block Pin
S	NLA	Blade, Single
	053	Blade Assembly, 3/16" (15 blades)
	054	Blade Assembly, 1/4" (11 blades)
	056	Blade Assembly, 3/8" (8 blades)

NLA = Part no longer available through The Vollrath Company, LLC.

EXPLODED VIEW - TOMATO KING

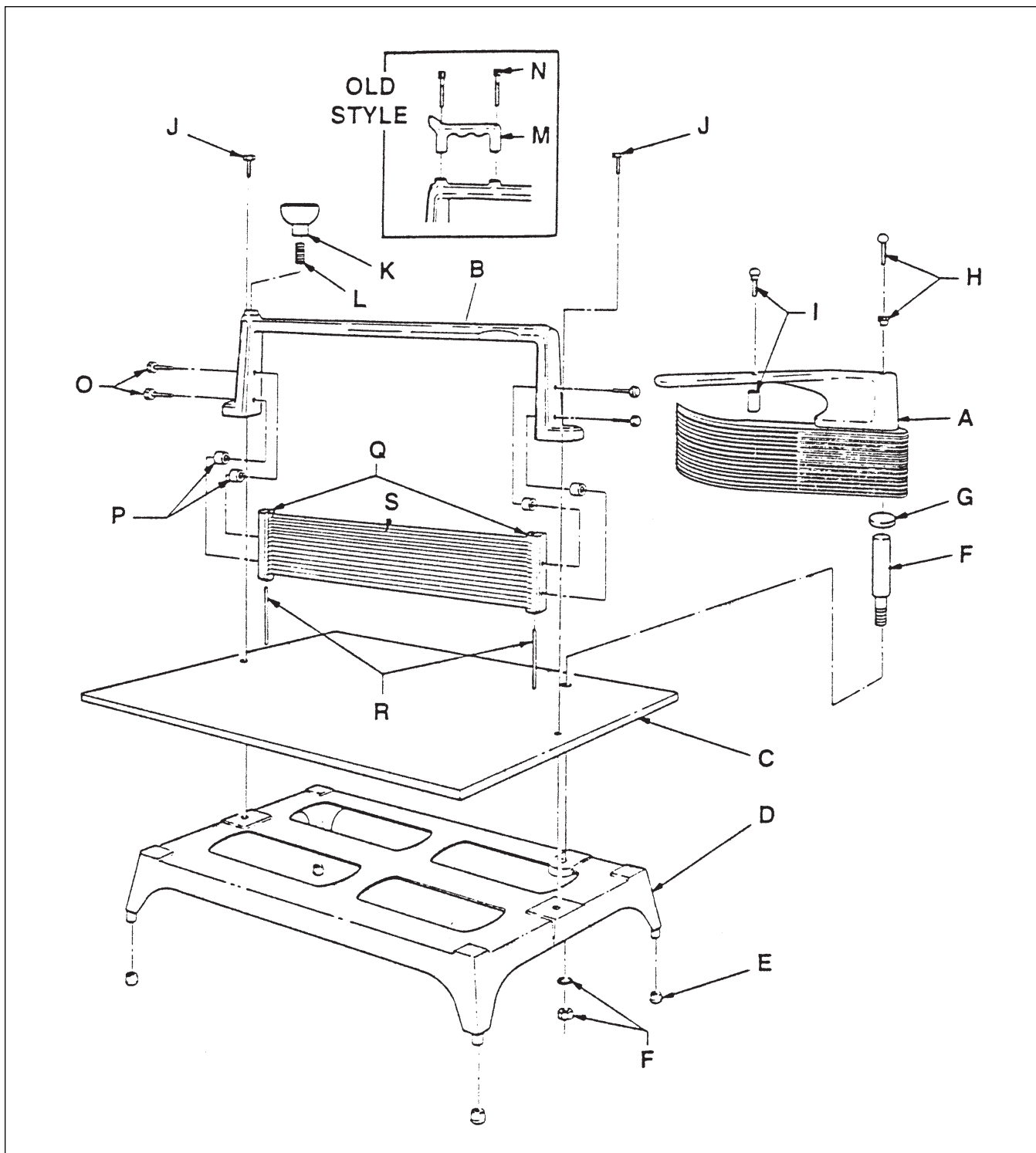

WARRANTY STATEMENT FOR THE VOLLRATH Co. L.L.C.

This warranty does not apply to products purchased for personal, family or household use, and The Vollrath Company LLC does not offer a written warranty to purchasers for such uses.

The Vollrath Company LLC warrants each of its products listed below against defects in materials and workmanship for the applicable period provided below. All other products manufactured or distributed by The Vollrath Company LLC are warranted against defects in materials and workmanship for a period of one year. In all cases, the warranty runs from the date of the end user's original purchase found on the receipt. Any damages from improper use, abuse, modification or damage resulting from improper packaging during return shipment for warranty repair will not be covered under warranty.

- Vollrath – Redco® products – The warranty period is 2 years
- Replacement parts – The warranty period is 90 days
- No remedy for normal use wear and tear or other causes not arising from defective material or workmanship. These components may be warranted if manufactured defective or due to material defect.

For complete warranty information, product registration and new product announcement, visit www.vollrath.com.



www.vollrath.com

The Vollrath Company, L.L.C.
1236 North 18th Street
Sheboygan, WI 53081-3201
U.S.A.

Main Tel: 800.628.0830
Fax: 800.752.5620

Technical Services: 800.628.0832
Service Fax: 920.459.5462

Canada Service: 800.695.8560

© 2014 The Vollrath Company, L.L.C.