



G Series VH Grinder

Fast, Precision Grinders with Visual Hoppers

GVH-1, GVH-2 & GVH-3



INSTALLATION & OPERATING GUIDE

For Technical Service, contact Bunn-O-Matic Corporation at 1-800-286-6070.

Bunn-O-Matic Corporation

Post Office Box 3227, Springfield, Illinois 62708-3227

Phone (217) 529-6601 | Fax (217) 529-6644

BUNN-O-MATIC COMMERCIAL PRODUCT WARRANTY

Bunn-O-Matic Corp. ("BUNN") warrants equipment manufactured by it as follows:

- 1) All coffee and tea dispensers/servers, MCR/MCP/MCA single cup brewers, and BUNNlink® electronic circuit and/or control boards – 1 year parts and 1 year labor.
- 2) Product-specific warranties for Premia™, Crescendo®, Fast Cup®, Sure Immersion®, Sure Tamp® and others – 1 year parts and 1 year labor. Please visit commercial.bunn.com/support/warranty-lookup for further details.
- 3) All other equipment – 2 years parts and 1 year labor plus added warranties as specified below:
 - a) Electronic circuit and/or control boards – parts and labor for 3 years.
 - b) Compressors on refrigeration equipment – 5 years parts and 1 year labor.
 - c) Grinding burrs on coffee grinding equipment for 4 years or 40,000 pounds of coffee, whichever comes first.
- 4) For customers subscribed to BUNNlink®, BUNN reserves the right to periodically auto-push critical software updates that will enhance functionality or performance of the BUNN equipment, unless the customer requests advance notice of such software updates from BUNN in writing.

These warranty periods run from the date of installation. BUNN warrants that the equipment manufactured by it will be commercially free of defects in material and workmanship existing at the time of manufacture and appearing within the applicable warranty period. This warranty does not apply to any equipment, component or part that was not manufactured by BUNN or that, in BUNN's judgment, has been affected by misuse, neglect, alteration, improper installation or operation, improper maintenance or repair, non periodic cleaning and descaling, equipment failures related to poor water quality, damage or casualty. In addition, the warranty does not apply to replacement of items subject to normal wear with use including but not limited to user replaceable parts such as seals and gaskets. This warranty is conditioned on the Buyer 1) giving BUNN prompt notice of any claim to be made under this warranty by telephone at (217) 529-6601 or by writing to Post Office Box 3227, Springfield, Illinois 62708-3227; 2) if requested by BUNN, shipping the defective equipment prepaid to an authorized BUNN service location; and 3) receiving prior authorization from BUNN that the defective equipment is under warranty.

THE FOREGOING WARRANTY IS EXCLUSIVE AND IS IN LIEU OF ANY OTHER WARRANTY, WRITTEN OR ORAL, EXPRESS OR IMPLIED, INCLUDING, BUT NOT LIMITED TO, ANY IMPLIED WARRANTY OF EITHER MERCHANTABILITY OR FITNESS FOR A PARTICULAR PURPOSE. The agents, dealers or employees of BUNN are not authorized to make modifications to this warranty or to make additional warranties that are binding on BUNN. Accordingly, statements by such individuals, whether oral or written, do not constitute warranties and should not be relied upon.

If BUNN determines in its sole discretion that the equipment does not conform to the warranty, BUNN, at its exclusive option while the equipment is under warranty, shall either 1) provide at no charge replacement parts and/or labor (during the applicable parts and labor warranty periods specified above) to repair the defective components, provided that this repair is done by a BUNN Authorized Service Representative; or 2) shall replace the equipment or refund the purchase price for the equipment.

THE BUYER'S REMEDY AGAINST BUNN FOR THE BREACH OF ANY OBLIGATION ARISING OUT OF THE SALE OF THIS EQUIPMENT, WHETHER DERIVED FROM WARRANTY OR OTHERWISE, SHALL BE LIMITED, AT BUNN'S SOLE OPTION AS SPECIFIED HEREIN, TO REPAIR, REPLACEMENT OR REFUND.

In no event shall BUNN be liable for any other damage or loss, including, but not limited to, lost profits, lost sales, loss of use of equipment, claims of Buyer's customers, cost of capital, cost of down time, cost of substitute equipment, facilities or services, or any other special, incidental or consequential damages.

CONTENTS

| | |
|--|----|
| NORTH AMERICAN REQUIREMENTS | 4 |
| CE REQUIREMENTS | 4 |
| USER NOTICES | 5 |
| ELECTRICAL REQUIREMENTS | 6 |
| OPERATING CONTROLS | 6 |
| Grind Selector | 6 |
| Off/On/Start Switch | 6 |
| Bag/Brew Cup Switch | 6 |
| Cleaning Lever | 6 |
| Bag Clamp | 6 |
| INITIAL SETUP | 7 |
| BURR ADJUSTMENT | 8 |
| COFFEE GRINDING | 8 |
| CLEANING | 9 |
| Weekly | 9 |
| 6 Month Cleaning | 9 |
| PREVENTIVE MAINTENANCE | 9 |
| DECAL INSTALLATION INSTRUCTIONS | 10 |
| REPLACING THE STANDARD CHUTE WITH THE OPTIONAL TRIFECTA® KIT | 11 |
| WIRING SCHEMATIC | 12 |

NORTH AMERICAN REQUIREMENTS

- This appliance must be installed in locations where it can be overseen by trained personnel.
- For proper operation, this appliance must be installed where the temperature is between 41°F to 95°F (5°C to 35°C).
- Appliance shall not be tilted more than 10° for safe operation.
- An electrician must provide electrical service as specified in conformance with all local and national codes.
- This appliance must not be cleaned by pressure washer.
- This appliance can be used by persons if they have been given supervision or instruction concerning use of the appliance in a safe way and if they understand the hazards involved.
- Keep the appliance and its cord out of reach of children.
- Appliances can be used by persons with reduced physical, sensory or mental capabilities or lack of experience and knowledge if they have been given supervision or instruction concerning use of the appliance in a safe way and understand the hazards involved.
- If the power cord is ever damaged, it must be replaced by the manufacturer or authorized service personnel with a special cord available from the manufacturer or its authorized service personnel in order to avoid a hazard.
- Machine must not be immersed for cleaning.
- This appliance is intended for commercial use in applications such as:
 - staff kitchen areas in shops, offices and other working environments
 - by clients in hotel and motel lobbies and other similar types of environments
- Access to the service areas permitted by Authorized Service personnel only.

CE REQUIREMENTS

- This appliance must be installed in locations where it can be overseen by trained personnel.
- For proper operation, this appliance must be installed where the temperature is between 5°C to 35°C.
- Appliance shall not be tilted more than 10° for safe operation.
- An electrician must provide electrical service as specified in conformance with all local and national codes.
- This appliance must not be cleaned by water jet.
- This appliance is not intended for use by persons (including children) with reduced physical, sensory or mental capabilities, or lack of experience and knowledge, unless they have been given instructions concerning use of this appliance by a person responsible for its safety.
- This appliance is intended to be used for commercial applications, for example in kitchens of restaurants, canteens, hospitals and in commercial enterprises such as bakeries, butcheries, etc., but not for continuous mass production of food.
- Children should be supervised to ensure they do not play with the appliance.
- If the power cord is ever damaged, it must be replaced by the manufacturer or authorized service personnel with a special cord available from the manufacturer or its authorized service personnel in order to avoid a hazard.
- Machine must not be immersed for cleaning.
- Machine rated IX P1.

USER NOTICES

Carefully read and follow all notices on the grinder and in this manual. They were written for your protection. All notices on the grinder are to be kept in good condition. Replace any unreadable or damaged labels.

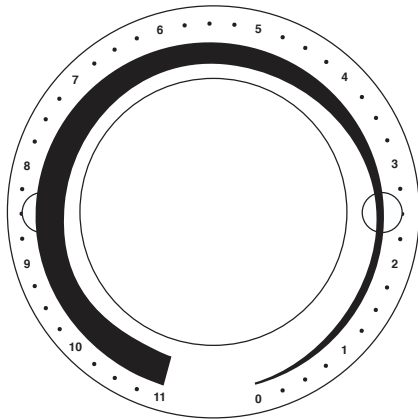

55071.0000

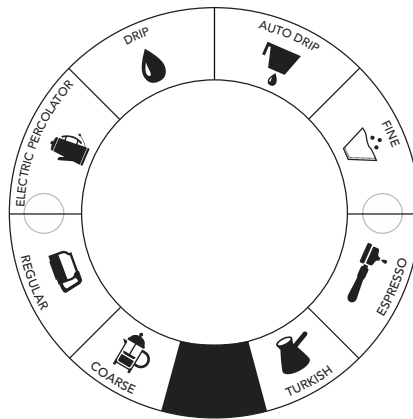

55071.0001

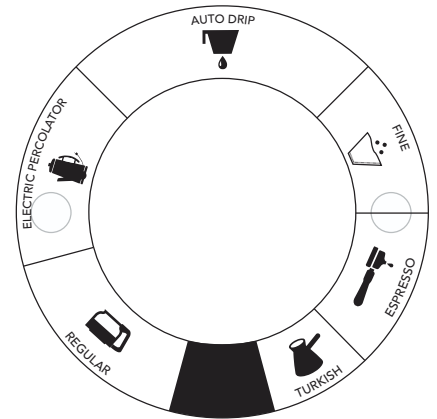

55071.0002
(Turkish)

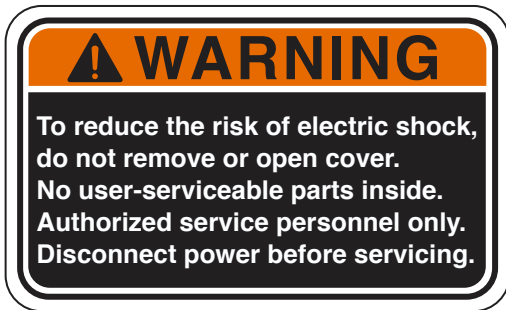

37881.0000



00824.0002



20545.0000



11076.0000

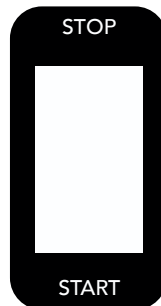

55072.0000



55405.0000

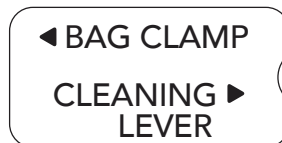

55073.0000

1. Select desired grind
2. Lift lid and pour coffee beans into hopper
3. Place your bag on tray under chute or into BAG CLAMP
4. Press START
5. To remove residual coffee from chute as dispensing slows, move CLEANING LEVER up/down several times
6. Remove your bag or container, grinder will automatically stop

55074.0000

ELECTRICAL REQUIREMENTS

CAUTION - The grinder must be disconnected from the power source until specified in *Initial Setup*. Refer to Data Plate on the Brewer, and local/national electrical codes to determine circuit requirements.

**100V & 120V
Models**



**220 - 240V
CE Models**



**220-240V
CE Models**



NOTE: This electrical service consists of 2 current carrying conductors (L1 and Neutral) and a separate conductor for chassis ground.

OPERATING CONTROLS

GRIND SELECTOR

Allows the user to vary the grind for each coffee. Each setting will provide precisely the same grind every time it is selected.

OFF/ON/START SWITCH

STOP/OFF - (upper position) Switching to this position stops the operation of the grinder.

ON - (center, resting position) The switch will return to this position after a grind cycle has begun and will remain in this position after grinding has ceased.

START - (lower, momentary position) Pressing the switch initiates grinding only when a bag or other container is in place behind the chute or if using the optional trifecta kit; the brew cup is in place.

BAG/BREW CUP SWITCH

Prevents the grinder from operating unless the back of a bag is in place behind the dispense chute or the optional trifecta brew cup is not in place. Do not attempt to bypass this safety device.

CLEANING LEVER

Allows the operator to clean out any coffee residue left from the previous grind.

BAG CLAMP

Allows the operator to clamp the coffee bag in place and not have to hold it during the grind operation.

INITIAL SETUP

CAUTION - Unplug the grinder throughout the initial setup.

1. Open the top lid. Clear all foreign objects and shipping materials from the hopper compartment.
2. Remove the black safety plug (located in the entrance to the grind chamber), before installing the hopper.

Here are the steps:

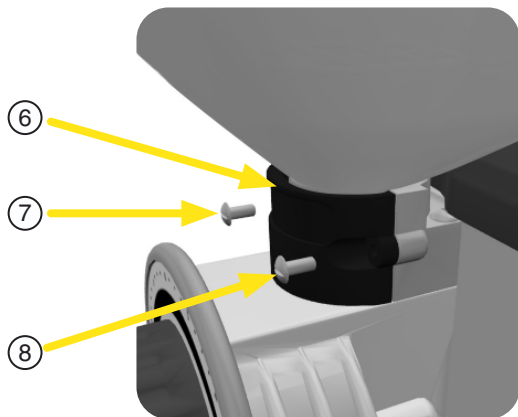
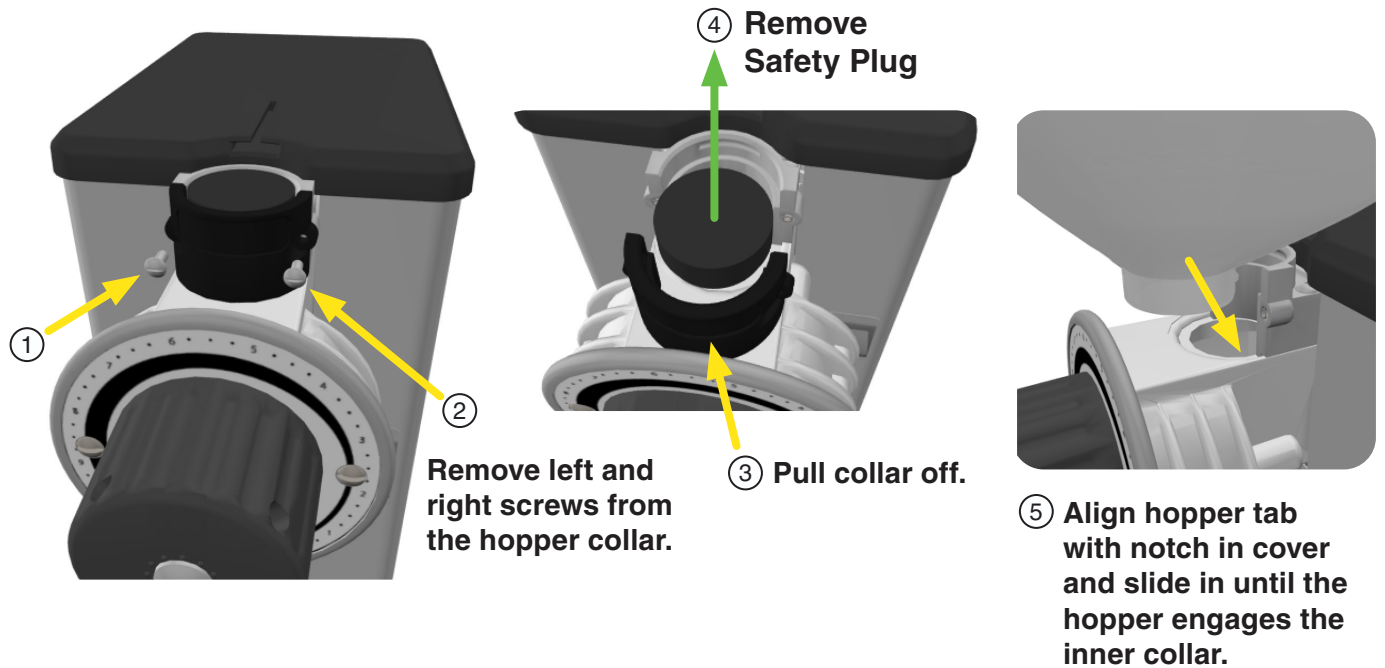

Replace the outer hopper collar, then the two screws.



The hopper is now in ready.

3. The grinder can now be plugged-in and put into service.

NOTE: If the grinder needs calibrated, follow the **BURR ADJUSTMENT** steps on the next page.

BURR ADJUSTMENT

1. Place an empty bag in place on the screen, with the back of the bag behind the dispense chute. If you have the optional tripecta kit, place the brew cup into holder.
2. Start the grinder to clear the grind chamber. Leave grinder "ON".
3. Turn the Grind Selector knob to the "0" (or "TURKISH" if using the symbol based decal) position.
4. Using a small flat blade screwdriver, loosen the two set screws on the left side of the grind selector knob.
5. Hold the knob in the "0" (or "TURKISH" if using the symbol based decal) position with one hand.
6. Using a large flat blade screwdriver, slowly turn the adjusting screw in the center of the grind selector knob to the right (clockwise) until a metallic whine can be heard due to the rubbing of the grinding burrs.
7. While holding the knob in the "0" (or "TURKISH" if using the symbol based decal) position, back off the screw to the left (counterclockwise) just until the metallic whine ceases.
8. Turn-off the grinder.
9. Push the knob against the dial plate and tighten both set screws on the left side of the grind selector knob.
10. Turn the grinder on and listen again for the metallic whine with the grind selector knob in the "0" (or "TURKISH" if using the symbol based decal) position. If the metallic whine is heard, repeat steps 7 through 10 until the sound ceases.
11. If no metallic whine is heard, the grinding burrs are adjusted properly. On tripecta models, you should hear a slight chirp of the burrs contacting if you rotate the knob fully clockwise past the "1" position.

COFFEE GRINDING

1. Load the desired weight or volume of beans into the bean hopper.
2. Turn the selector knob to align the arrow with the desired grind size.
3. Press down on the lever to open the bag clamp bracket.
4. Locate bag between the rear of the chute and the clamp bracket, then release the lever. (The grinder will not operate unless the bag sensor is activated)
5. Press the start switch.
6. Flip the cleaning lever a few times as dispensing slows.
7. Remove the bag or brew cup when ground coffee is no longer dispensed from the chute. The grinder will stop automatically as the bag or brew cup is removed.

NOTE - For proper operation wait until the motor stops spinning before pressing the start switch to begin the next grind sequence.

CLEANING

Weekly

Clean all exterior surfaces using a damp cloth rinsed in any mild, nonabrasive, liquid detergent. Care should be taken not to scratch the grinder with any abrasive material.

6 Month Cleaning

1. Empty all beans from hopper.
2. Plug in the grinder.
3. Place an empty bag behind the dispense chute or trifacta brew cup.
4. Press and release the "START" switch.
5. Run a few cycles until all coffee in the grind chamber is dispensed.
6. Remove the bag or brew cup.

WARNING - Prior to cleaning the grind chamber, unplug the grinder.

7. Remove the two screws and remove the dial plate and selector knob assembly.
8. Slide the burr auger rotor/spring assembly off the motor shaft and disassemble for cleaning.
9. Remove the two screws securing the stationary burr to the grind chamber.
Inspect and clean/replace burrs if necessary.
10. Remove the four screws at the top of the chute and remove the chute. Use a stiff non-metallic bristle brush to remove any debris around the flapper.
11. Wash all parts in a mild solution of detergent with hot water and a stiff non-metallic bristle brush.
12. Rinse all parts thoroughly and allow them to air dry before reinstalling.
13. Carefully clean the grind chamber, dial plate assembly, and chute opening with a dry stiff non-metallic bristle brush.
14. Wipe with a clean cloth that has been soaking in a mild solution of detergent and hot water.
15. Reinstall the chute onto the burr housing.
16. Reinstall the stationary burr to the grind chamber.
17. Reinstall the spring and outer burr onto the auger rotor.
18. Align the slot in the motor shaft with the rotor and reinstall shear plate.
19. Reinstall rotor cup and grind selector dial plate to the burr housing.
Refer to the "BURR ADJUSTMENT" section to adjust burrs.

PREVENTIVE MAINTENANCE

Bunn-O-Matic® Corporation recommends performing preventive maintenance at regular intervals. Maintenance must be performed by a qualified technician. For technical service, contact Bunn-O-Matic Corporation at 1-800-286-6070.

NOTE: The warranty does not cover replacement parts or service caused by failure of the maintenance required.

Every 6 months or more often if necessary

- Check and clean the grinder chamber every 6 months or more often if needed.
- Inspect and clean or replace burrs, if necessary.
- Carry out a zero adjustment of the coffee grinder to ensure that the accuracy of the grind is retained.

DECAL INSTALLATION INSTRUCTIONS

If preferred, the numbered dial decal can be replaced with the symbols dial decal included with the grinder. Here are the steps to exchange them:



① Turn knob clockwise till indicator points to zero.



② Remove left screw on knob.



③ Remove right screw on knob.

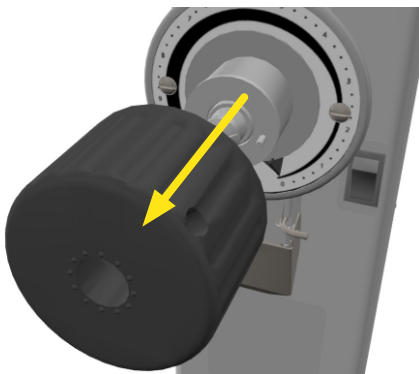

④ Remove the knob.

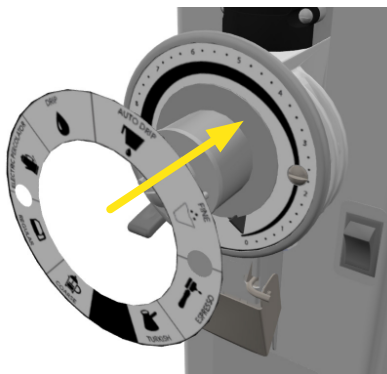

⑤ Pull the tab to remove the adhesive strip on the back of the symbols decal. Place the decal directly over the numbers decal.

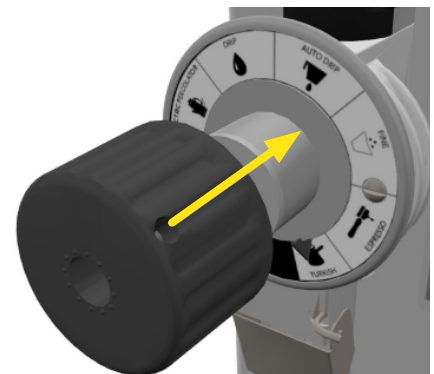

⑥ If the decal is placed in the correct location (the screws should both show through the decal), then press to adhere. Now, replace knob.



⑦ Replace right screw on knob.

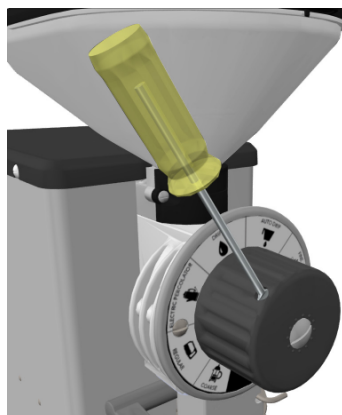

⑧ Replace left screw on knob.



The decal is ready.

NOTE: If needed, follow the BURR ADJUSTMENT instructions on page 8.

DECAL INSTALLATION INSTRUCTIONS

A “Grinding Instructions” decal is supplied.

This decal is required when installed in a protected location such as under a canopy, marquee, shelter or similar structure.

Here is the location for this decal:



A “Flavored Coffees ONLY” decal is supplied for use if preferred. Here is the location suggested for this decal:



REPLACING THE STANDARD CHUTE WITH THE OPTIONAL TRIFECTA® KIT

The standard chute can be switched out with the optional trifecta kit to be used with the trifecta single serve brewer. This kit has a holder for the trifecta cup (shown below).



① Remove four screws from below the number dial.

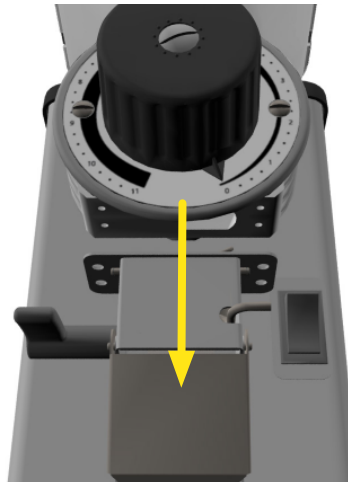

② Remove the chute.

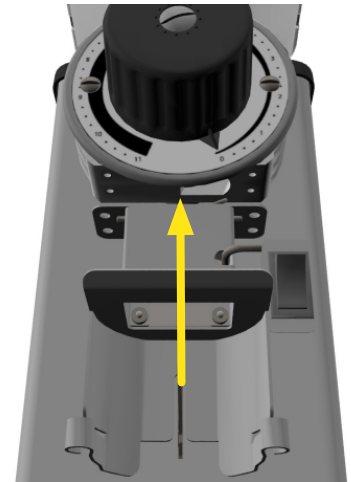

③ Replace with the trifecta chute.



④ Replace the four screws from below the number dial.

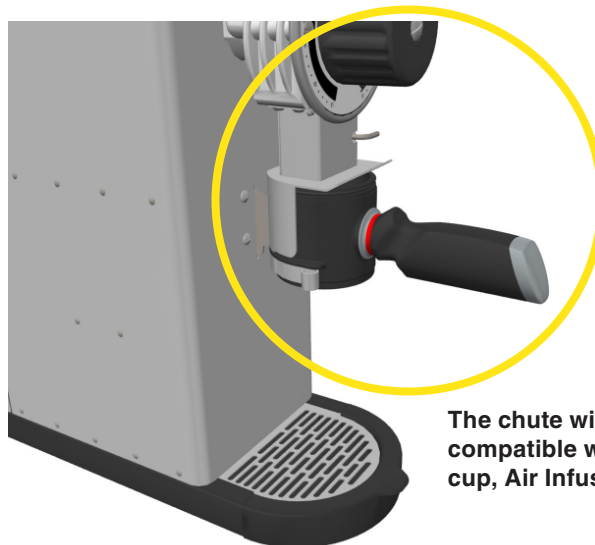

The chute will now hold the cup compatible with the trifecta® single cup, Air Infusion® brewer.

WIRING SCHEMATIC

SCHEMATIC WIRING DIAGRAM G1, G2, G3, G2 trifecta

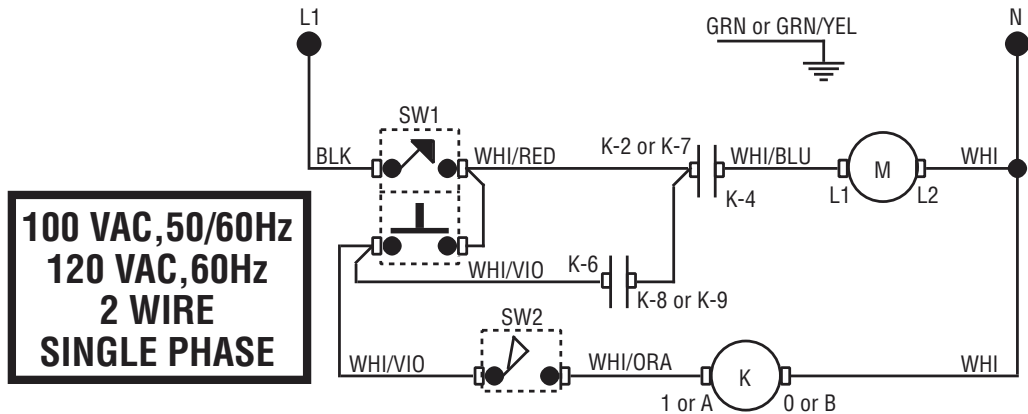

10190.0000 J 08/29/24 © 1985 BUNN-O-MATIC CORPORATION

SCHEMATIC WIRING DIAGRAM GVH-1, GVH-2, GVH-3

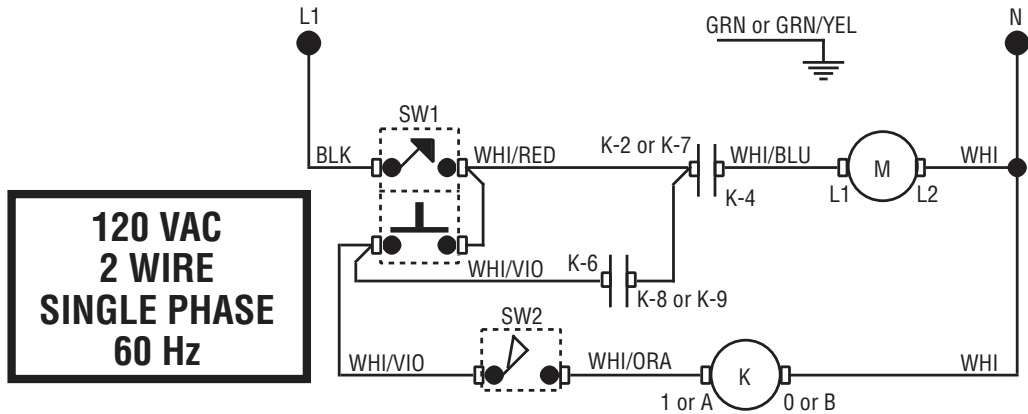

10190.0002 A 08/29/24 © 1985 BUNN-O-MATIC CORPORATION

SCHEMATIC WIRING DIAGRAM GVH-1A, GVH-2A, GVH-3A

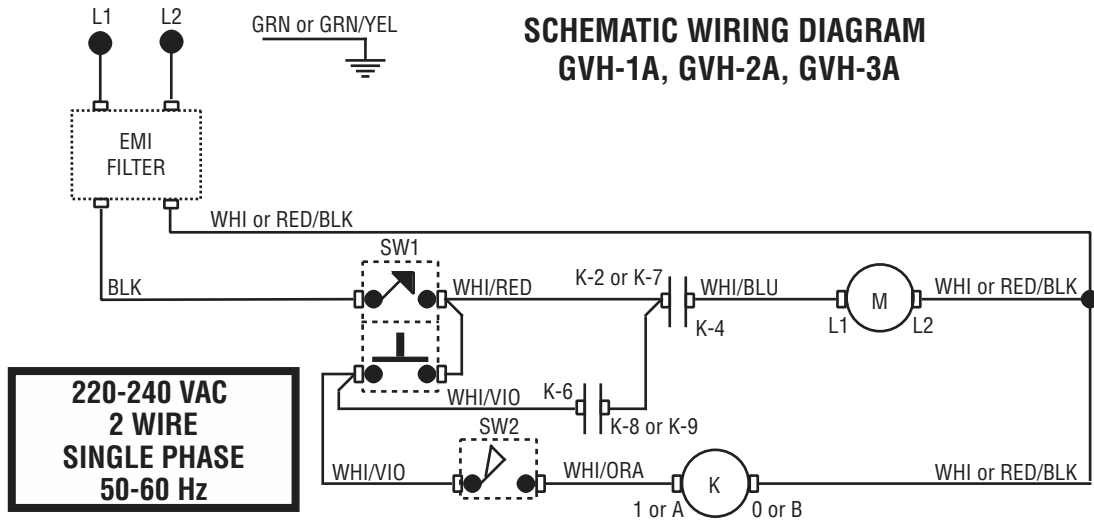

10190.0003 A 08/29/24 © 2012 BUNN-O-MATIC CORPORATION