



Apple Machine Operating Instructions & Recipe Guide



***Everything you need to know to operate your
Apple Paring, Coring, Slicing Machine.***

- *See pages 2-4 for operating instructions.*
- *See pages 6-7 for any troubleshooting questions you may have.*
- *See pages 8-9 for delicious recipes!*
- *See pages 10-11 for parts reference.*



This guide applicable to all models including:
860, 861, 864, 864R, 865, 865R, 866, 866R

**NORPRO IS PLEASED TO CONFIRM THAT
MANY NORPRO PARTS ARE AVAILABLE TO
CONSUMERS – EXCLUSIVELY THROUGH
HOME AND FARM SUPPLY
SIMPLY CALL HOME AND FARM KITCHEN
SUPPLY TEL. # 209-223-0264**

YOU CAN ALSO MAIL YOUR PARTS ORDER TO

**HOME AND FARM KITCHEN SUPPLY/ATTN:
NORPRO PARTS- 165 MAIN ST, JACKSON, CA
95642**

**AS A WHOLESALER, Norpro cannot accept calls or
emails from consumers for Norpro parts.**

**We are confident that your needs will be met by
Home and Farm kitchen Supply bt you may also
visit the retailer you purchased the product from for
parts, or your local kitchenware store.**

Thank you for choosing Norpro.

APPLE MASTER - MODEL 865 AND 866

OPERATING INSTRUCTIONS

TO PARE/CORE/SLICE

- 1- Remove Apple Master from box and clean with warm soapy water and dry thoroughly before use.
- 2- Attach the handle to the arm using a Phillips screw driver.
- 3- Mount the Apple Master to a smooth flat surface. Flip the lever to create a tight suction. (For model 865, you can use the optional clamp to clamp to table).
- 4- Push in shaft release lever in order to bring the 3 prong fork into start position. (See diagram 1)
- 5- Gently push the apple onto the 3 prong fork, stem first. Be sure the apple core is lined up with the hole in the corer/slicer blade. (See diagram 2)
- 6- Turn the handle clockwise. Continue turning until the apple is completely through the corer/slicer (see diagram 3). Minor blade adjustments may be needed if peel is too thin or thick (See pages 6-7 for details).
- 7- Remove sliced apple and core from 3 prong fork. Discard core.
- 8- Repeat steps 4-7 to peel/core/slice more apples.

TO PARE ONLY

Remove corer/slicer blade to allow paring knife to work alone, then follow instructions above.

TO CORE/SLICE ONLY

Pull paring knife holder back until it locks open to allow the corer/slicer to work alone (see diagram 1), then follow instructions above.

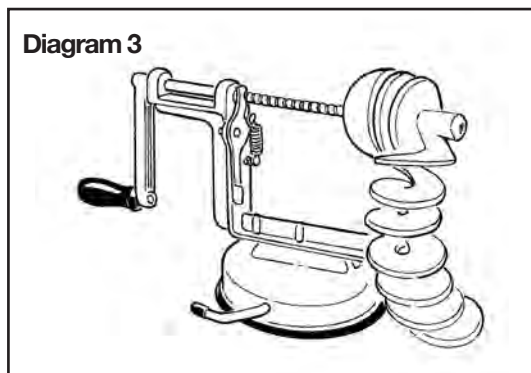
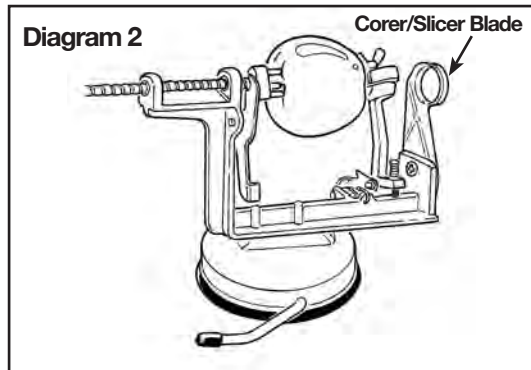
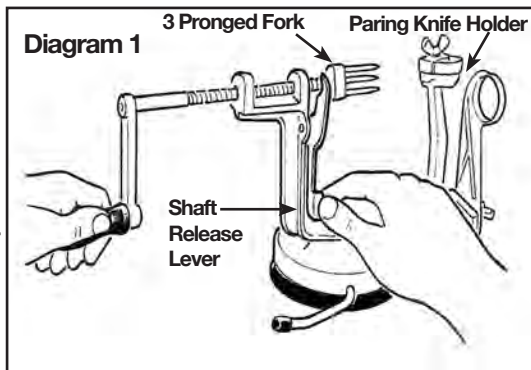

APPLE MATE I - MODEL 860

OPERATING INSTRUCTIONS

TO PARE/CORE/SLICE

- 1- Remove Apple Mate I from box and clean with warm soapy water and dry thoroughly before use.
- 2- Attach the handle to the arm using a Phillips screw driver.
- 3- Mount the Apple Mate I to the edge of a counter or table top up to 1.75"/4.5cm.
- 4- Push in shaft release lever in order to bring the 3 prong fork into start position.
(See diagram 1).
- 5- Gently push the apple onto the prong fork, stem first. Be sure the apple core is lined up with the hole in the corer/slicer blade.
(See diagram 2).
- 6- Turn the handle clockwise. Continue turning until the apple is completely through the corer/slicer. (See diagram 3). Minor blade adjustments may be needed if peel is too thin or thick (see pages 6-7 for details).
- 7- Remove sliced apple and core from 3 prong fork. Discard core.
- 8- Repeat steps 4-7 to peel/core/slice more apples.

TO PARE ONLY

Remove corer/slicer blade to allow paring knife to work alone, then follow instructions above.

TO CORE/SLICE ONLY

Pull paring knife holder by removing the screw and nut attached to it, then follow instructions above. For troubleshooting, see pages 6-7.

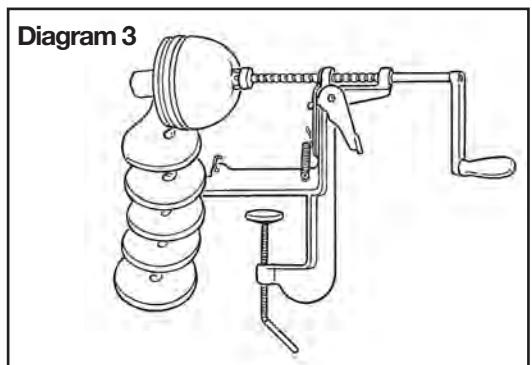
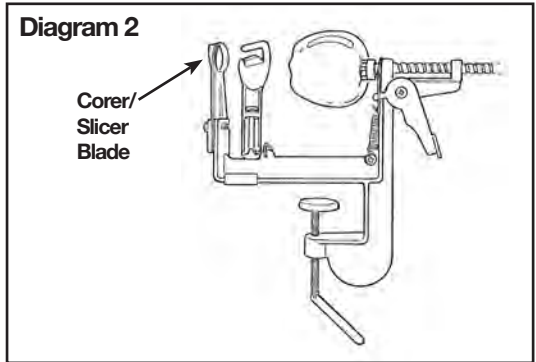
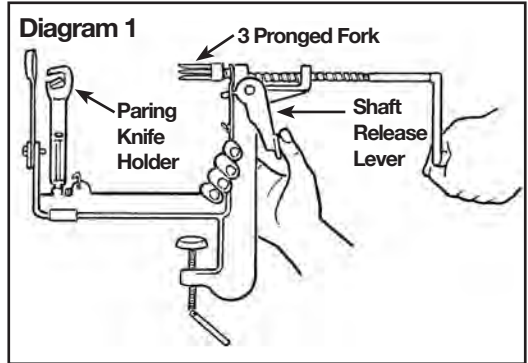

APPLE MATE II & III - MODELS 861 and 864

OPERATING INSTRUCTIONS

TO PARE/CORE/SLICE

- 1- Remove Apple Mate II or III from box and clean with warm soapy water and dry thoroughly before use.
- 2- Attach the handle to the arm using a Phillips screw driver.
- 3- Mount the Apple Mate II or III to the edge of a counter or table top up to 2"/5cm thick.
- 4- Push in shaft release lever in order to bring the 3 prong fork into start position. (See diagram 1).
- 5- Gently push the apple onto the 3 prong fork, stem first. Be sure the apple core is lined up with the hole in the corer/slicer blade. (See diagram 2).
- 6- Turn the handle clockwise. Continue turning until the apple is completely through the corer/slicer. (See diagram 3). Minor blade adjustments may be needed if peel is too thin or thick. See pages 6-7 for details.
- 7- Remove sliced apple and core from 3 prong fork. Discard core.
- 8- Repeat steps 4-7 to peel/core/slice more apples.

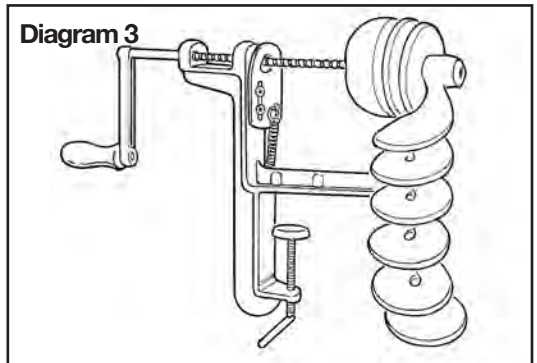
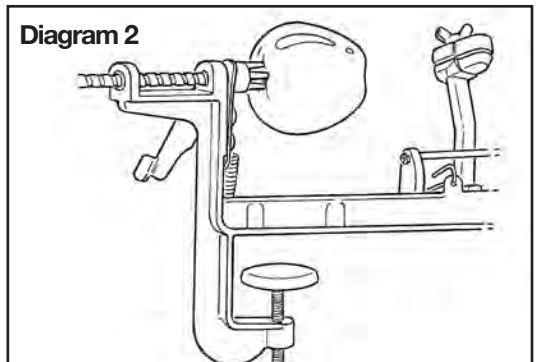
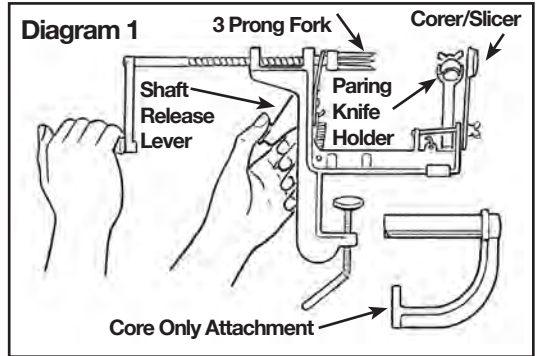

TO PARE ONLY

Remove corer/slicer blade to allow paring knife to work alone, then follow instructions above.

TO CORE/SLICE ONLY

Pull back paring knife holder past the retaining bar. The retaining bar will secure the arm back so that it does not make contact with the apple. Then follow instructions above.

TO CORE ONLY (for Apple Mate III only - Model 861)

1. Pull back paring knife holder past the retaining bar. The retaining bar will secure the arm back so that it does not make contact with the apple.
2. Remove corer/slicer blade by first removing the wing nut and metal plate.
3. Attach the core only attachment in place of the corer/slicer (See diagram 1).
4. Follow instructions above.

TO PARE AND CORE ONLY

(For Apple Mate III only - Model 861).

Follow the instructions for TO CORE ONLY, but use paring knife as well.

For troubleshooting, see pages 6-7.

"I would like to know what stores sell your Apple-Mate 2. I really want to buy one, my parents have one that I used as a kid. Please respond ASAP, I have three apple trees!"
Hugh Fairhurst
Minnesota

"I Received the 866 as a gift and love it. I will be buying more to use as gifts."

Pearl Taylor
California

"I was given an Apple Parer, Slicer, Corer for Christmas. I have used it relentlessly."

Valerie W. Blakely
Canada

"...we make about one pie per month and have had the machine 5-6 years. We like the machine very much and have purchased some for friends and relatives."

Joan Coates
Oregon

"I have used your 865 Apple Parer, Slicer, Corer for some time and find it to be a very useful tool"

W. Edward Allan
Washington

"I purchased your Apple-Mate 1 and just love it."

Sandra Brooks
Illinois

"My daughter-in-law has one of your Apple-Mates. I liked it very much...I was wondering if you could tell me where I could purchase one. Would be very grateful if I could find one."

Mrs. Ted Chrischilles
Iowa



TROUBLESHOOTING

To prevent damage, it is important that your Apple Machines be adjusted properly before each use. Refer to the following instructions each time you set up your machine and you will enjoy years of trouble free service.

All Models:

Be sure Slicer/Corer Blade is facing the right way.

When using the slicer/corer blade, be sure flanged end of blade faces away from 3 pronged fork and support plate is in proper position. (See diagram below).

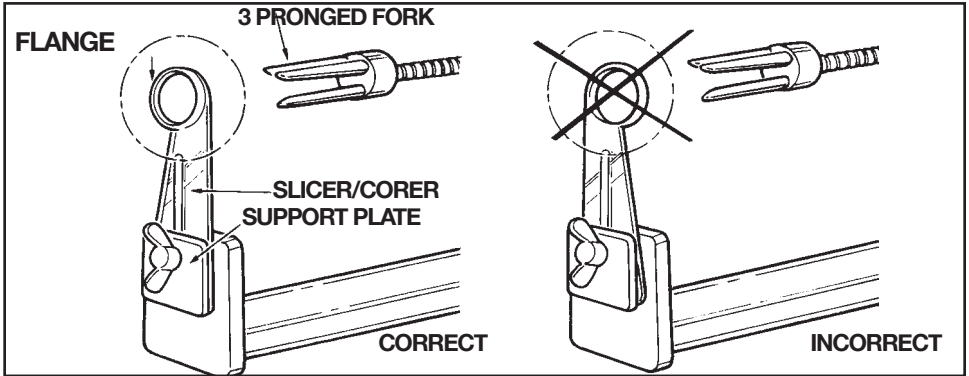

All Models:

Align Corer or Slicer/Corer Blade.

Release shaft release lever and push shaft all the way in. Align slicer/corer with the 3 pronged fork so that there is an even space all the way around the 3 pronged fork. (See diagram at right).

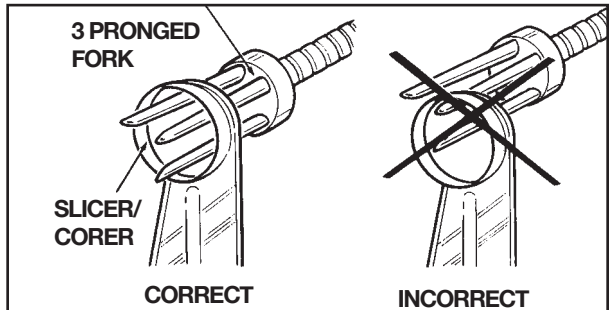

Model #860:

Face Paring Knife Blade the right way.

If paring knife blade has been removed for cleaning, be sure it is facing the right way before using. (See diagram at right).

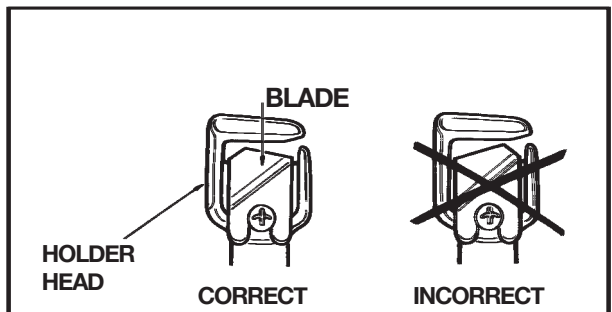

TROUBLESHOOTING

Models #861, 864, 865, 866

Adjust Paring Knife Blade:

The correct setting should have the peeling blade approximately even with the rounded end of holder. To adjust for proper peeling thickness for different variety of apples, loosen wing nut and move blade forward or back slightly, i.e. 1/32" until you obtain desired peeling depth. Make sure there is an even space between holder head and blade as shown. Hold firmly in desired position and tighten wing nut securely. Note: By moving blade forward (away from holder) more apple will be peeled and by moving blade back, less apple will be peeled. (See diagram above).

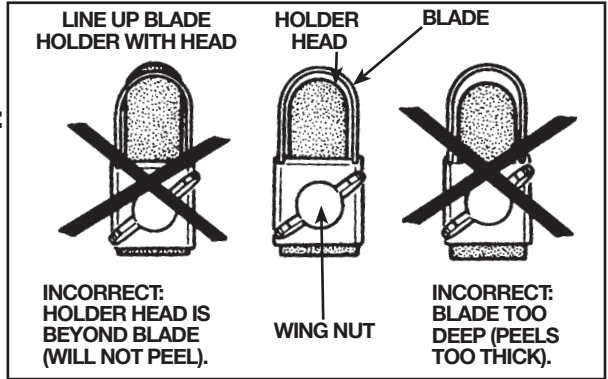

ALL MODELS:

Problem	Cause	Solution
Won't pare properly. Will not peel.	Paring blade needs cleaning. Paring blade not properly adjusted.	Rinse off paring blade. Adjust paring blade.
Parer removes too much fruit with peel.	Paring blade is set too deep.	Adjust paring blade for shallower cut. See diagram above.
Fruit breaks up before being completely sliced.	Fruit is too soft.	Use only fresh, hard fruit.
Part of core is sliced with fruit.	Fruit is not centered on 3 pronged fork.	Be sure fruit is centered on 3 pronged fork.
Won't core properly.	Coring blade not aligned properly.	Align coring blade.
Fruit won't slice.	Slicing blade is on backwards.	Be sure slicing blade is facing right way.

Care Instructions:

Apple juice is very sticky when dry, it is important for satisfactory operation the unit be hand washed and dried thoroughly after every use. If you are processing a large number of apples, it is recommended that you rinse and dry your machine occasionally.

RECIPES

*Pie-making is easy when using Norpro Apple Machines!
Look for more Norpro products for the rest of your bakeware needs.*

Basic Pie Crust

3 cups (320 g) sifted flour
1 cup (225g) veg. shortening or lard
3 tablespoons (45g) sugar
1/2 cup (118 ml) ice cold water

Cheesy Pie Crust

2 1/2 cups (350 g) sifted flour
3/4 cup (175 g) shortening
1/2 cup grated cheddar cheese
1/3-1/2 cup (79 ml-118 ml) ice cold water

Apple Pie Filling

5 large apples
2 tablespoons (60 ml) lemon juice
1/2 cup (100 g) brown sugar, packed
2 tablespoons (17.5 g) all purpose flour
1/2 teaspoon (2.5 g) cinnamon

1/2 teaspoon (2.5 g) nutmeg
1 tablespoon (15 g) butter
1 1/2 teaspoon (7.5 ml) milk
1 teaspoon (5 g) sugar

Preheat oven to 400°F/204°C. Grease a 9" pie plate. Make pie crust. Place flour in bowl. Cut in shortening with pastry blender until mixture resembles coarse crumbs. Using a blending fork, stir in water, a tablespoon at a time until dough forms a ball. Do not over mix. Divide in half and wrap in wax paper. Refrigerate 30 minutes. Meanwhile, make filling - peel, core and slice the apples using Norpro's Apple Machine. Cut slices into quarter pieces. Place in bowl and toss with lemon juice. Combine the brown sugar, flour, cinnamon and nutmeg. Take dough out of refrigerator and roll one into a 12" circle approximately 1/8" thick. Fold in half, place onto pie plate, and unfold. Brush crust with beaten egg white. Layer half the apple slices in the crust and sprinkle with half of the sugar mixture. Repeat the layers. Cut the butter into small pieces and scatter over the apples. Roll out the top crust, place over the filling, trim and flute edges. Make 3 steam vents in the center. Brush with milk and sprinkle with 1 teaspoon sugar. Cover with Norpro's Perfect Pie Crust Shield to protect edges while baking. Bake 50-60 minutes or until crust is golden brown. Cool and serve with vanilla ice cream.

RECIPES

Susie's Apple Cobbler

6 large apples
1 cup (140 g) flour
1 teaspoon (5 g) ground cinnamon
1 teaspoon (5 g) baking powder

1/2 cup (100 g) sugar
1/2 cup (100 g) brown sugar
1 large egg
1/3 cup (85 g) melted butter or margarine

Preheat oven to 350°F/177°C. Grease a 2 quart baking dish. Peel, core and slice the apples into 1/4" pieces. In a medium size bowl, mix the flour, cinnamon, baking powder and the sugars. Beat the egg lightly and stir into the sugar mixture. Spoon on top of the sliced apples. Pour melted butter over mixture and bake for 45 minutes.

Dehydrating Apple Slices

Peel, core and slice apples into 1/4" pieces. Arrange in layers (no more than 1/2" deep) on drying trays. In a dehydrator or a regular oven, dry at temperatures between 120°F/49°C and 140°F/60°C. At 140°F/60°C (higher temperatures bake the slices) it will take approximately 6 hours for the slices to dry thoroughly. If you want to do it overnight, set the temperature at 120°F/49°C. For evenly dried slices, turn them occasionally on the trays.

Apple-Cheese Pizza

Pastry for a single pie crust

5 large apples
1/2 cup (60 g) grated cheddar cheese
1/2 cup (118 g) chopped walnuts
1/2 cup (118 g) oatmeal

1/2 cup (100 g) brown sugar
1/2 teaspoon (2.5 g) ground cinnamon
1/2 teaspoon (2.5 g) ground nutmeg
3 tablespoons (45 g) butter

Preheat oven to 400°F/204°C. Grease a 12" pizza pan. Roll the pastry into a 13" circle and place on the greased pizza pan. Form a rim around the edge. Bake in the oven for 10 minutes. Peel, core and slice the apples into 1/4" pieces. Arrange on the pizza crust and sprinkle with the grated cheese. Mix together the walnuts, oatmeal, brown sugar and spices. Sprinkle on top of the cheese. Dot pieces of butter over the top and bake for 20 minutes, or until the apples are tender. Serve hot.

See diagrams on Page 11 for reference to machine parts.

Part Letter	Description
A1R, A1E	Red Cap, Black Cap
B1	Shaft Release Lever
C1	Draw Shaft - Standard with 860, 861 and 864
D1, D2	3 Pronged Fork
E1, E1R, E2, E2R, E3	Paring Knife Holder
F1, F2	Slicer/Corer
G1R, G1E	Handle
H1, H1R	Metal Arm
I1	Handle Bolt
L1	Wing Bolt
L2	Wing Nut, Bolt and Washer
M1	Square Metal Plate to hold F
N1	Retaining Bar and Nut
N2	Retaining Hook
P1	Shaft Guide Plate
Q1	Spring for Shaft Guide Plate
Q2	Spring for Shaft Release Lever
R1	Rubber Foot
S1	Vacuum Base
Y1	Flat Paring Blade - Fits 860 only
Z1	Paring Knife
#861C	Coring Attachment - Fits 861 & 864
#867	Optional Thick Slice Shaft (Cuts 1/8" slices) Comes standard with 865 & 866 series

