

48" RESTAURANT RANGES WITH 26 1/2" OVEN

GAS TYPE: NATURAL LP



- AR-8-126L-SBR
- AR-12G-6B-126L-SBR
- AR-24G-4B-126L-SBR
- AR-36G-2B-126L-SBR
- AR-48G-126L-SBR

STANDARD FEATURES

- Commercial gas range 48" wide and 32 1/2" depth
- Cooking height 36"
- Stainless steel sides, front, and 6" deep front landing ledge
- Adjustable 6" legs
- Choose: 6" high stainless steel stub back, high riser, or high riser with shelf at no charge
- Two year limited warranty, parts, and labor
- Base options: Standard, convection, or storage base

OPEN BURNERS

- 12" x 12" cast-iron top grates
- 32,000 BTU/hr. lift-off open burners
- Removable full width drip pan under burner

STANDARD OVEN

- Steel oven burner rated at 35,000 BTU/hr.
- Oven dimensions: 20"W x 26 1/2"D x 13 1/2"H
- Thermostat ranging from 250°F to 500°F (121°C to 260°C)
- Oven Door: Spring assisted, counterweight door
- Two chrome plated oven racks (Additional racks optional)
- Two fixed rack positions
- Porcelain enamel oven interior for easy cleaning
- 100% safety gas shut off

CONVECTION OVEN *(In place of standard oven)*

- Steel oven burner rated at 30,000 BTU/hr.
- Convection oven fan improves heat transfer for a faster cook time
- Thermostat ranging from 250°F to 500°F (121°C to 260°C)
- Two chrome plated oven racks (Additional racks optional)
- Chrome rack guides with five tray positions

GRIDDLES

- 1" thick steel griddle plate
- 3" wide grease collector
- One burner every 12", rated at 20,000 BTU/hr.
- Manual control valve for each burner
- Optional : Thermostatic griddle with modulating thermostat

AVAILABLE OPTIONS

- Swivel Casters (Set of four – two with front brakes)
- Storage Cabinet Base (In place of standard oven)
- Thermostatic Control Griddle



Model Shown AR-12G-6B-126L-SBR

Shown with optional casters

DESCRIPTION

American Range, restaurant range size 48" x 32-1/2" x 56" Stainless steel front, sides, backriser, shelf, and 6" adjustable legs. Removable full width drip pan. Choose 32,000 BTU/hr. open burners with lift-off burner heads or 20,000 BTU/hr. 12" section griddle or a combo burner griddle. Heavy-duty cast iron grates, 12" x 12". Burner knobs are cool to the touch, high temperature material. One oven: 35,000 BTU/hr. standard oven, or 30,000 BTU/hr. for convection with porcelain interior and inside door panel, oven interior measures 26-1/2"W x 22-1/2"D x 13-1/2"H. Oven thermostat adjusts from 250°F to 500°F. All ovens supplied with two racks. Oven door with a spring assisted, counterweight mechanism requiring no adjustment. Rear gas connection and pressure regulator.



48" RESTAURANT RANGES with 26 1/2" oven and storage base

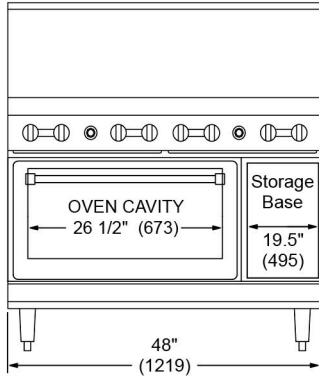

Front Standard 26 1/2" Oven and Storage Base

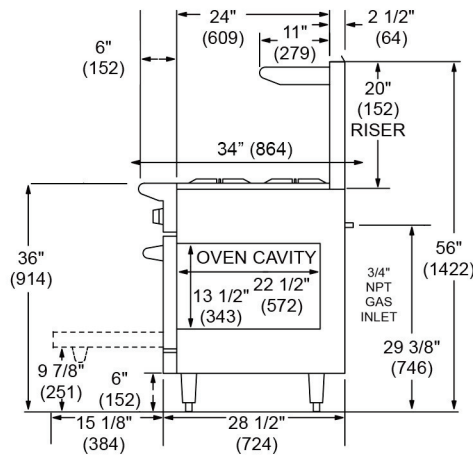

Side Standard Oven Base

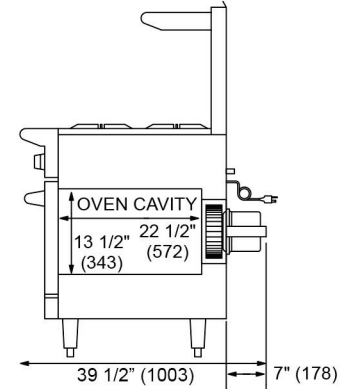

Side Convection Oven Base

TOP	MODEL	BTU/hr.	(KW)	BURNERS	GRIDDLE SIZE	Shipping Weight*	
						LBS	(KG)
	AR-8-126L-SBR	291,000	(86)	8	N/A	570	(259)
	AR-8-CL-SBR	286,000	(84)	8	N/A	570	(259)
	AR-12G-6B-126L-SBR	247,000	(73)	6	12" (305 MM)	585	(265)
	AR-12G-6B-CL-SBR	242,000	(71)	6	12" (305 MM)	585	(265)
	AR-24G-4B-126L-SBR	203,000	(60)	4	24" (610 MM)	590	(268)
	AR-24G-4B-CL-SBR	198,000	(58)	4	24" (610 MM)	590	(268)
	AR-36G-2B-126L-SBR	159,000	(47)	2	36" (914 MM)	605	(274)
	AR-36G-2B-CL-SBR	154,000	(45)	2	36" (914 MM)	605	(274)
	AR-48G-126L-SBR	115,000	(34)	N/A	48" (1219 MM)	620	(281)
	AR-48G-CL-SBR	110,000	(32)	N/A	48" (1219 MM)	620	(281)

"C" = Convection Oven, "SB" = Storage Base, "G" = Manual Griddle Top.
Griddle on the left, storage base on the right.

Combo base options available – choose standard, convection ovens, or storage base.
Contact factory for other options.

COMBUSTIBLE WALL CLEARANCES: For use only on noncombustible floors. Legs or casters are required, or 2" (51) overhang is required when curb mounted. Clearance from non-combustible walls is 0". When unit is placed next to combustible walls, clearances must exceed 12" (305) from sides, and 4" (102) from rear. Commercial cooking equipment requires an adequate ventilation system. For additional information, refer to the National Fire Protection Association's standard, NFPA96 "Vapor Removal from Cooking Equipment." (NOTE: For North America only)

CONVECTION OVEN ELECTRICAL		
VOLTAGE	PHASE	AMPS
120	1	4

15 amps three prong cord provided

MANIFOLD PRESSURE		
NATURAL GAS	PROPANE GAS	MANIFOLD SIZE
5.0" W.C.	10.0" W.C.	3/4" (19MM)

Specify type of gas and altitude if over 2000 feet.
Please specify gas type when ordering.

*Shipping weight includes packaging and is approximate.

