



# LOW TEMPERATURE ENERGY SAVER SINGLE RACK DISHWASHER

## EST-VL

Chemical Sanitizing  
Energy Saver Dishwasher



### CMA MODEL: EST-VL

The Ventless process eliminates the installation cost of a hood/fan, annual operational cost of the hood/fan, and hood ventilation system cost. Water entering the booster heater has been pre-heated, reducing the energy cost to bring booster temperature to required 120 degrees, potentially saving THOUSANDS of \$ in operation costs. NO VENT HOOD REQUIRED. Save THOUSANDS of \$ on installation.

### FEATURES

- The HR System (Waste Air Heat Recovery) removes heat and water vapor that normally would be released when opening the dishmachine doors, utilizing that energy to preheat the incoming water; this saves energy while creating a safer and more comfortable environment.
- High tech condensation method converts the vapor to water, which evacuates the wash chamber at the end of the cycle.
- Three-door system for straight-thru or corner applications.
- Built-in "booster heater" assures proper wash and rinse temperatures (does not "tax" facilities' hot water supply).
- Auto Start System.
- Programmable (three-product) Dispensing System.
- Water Saving (1.09 gallons of water per rack of dishes).
- Automatic HR Condenser Cleaning System for daily coil wash-down.
- 30 racks per hour (90-second cycle and 30-second chamber purge).
- Top mounted controls.
- Door Safety Interlock System (DSI) assures that doors remain locked throughout the entire cycle, allowing the HR system to evacuate the vapor from the machine.

### AVAILABLE OPTIONS

- Stainless Steel Dishtables
- Alternative Electrical Available



Low Chemical Alarm

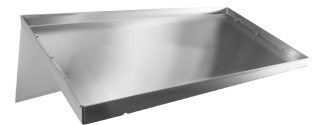

Universal Slant Shelf





**EST-VL**  
**ENERGY SAVER**  
 Ventless  
 Low Temperature  
 Single Rack Dishwasher

**WARNINGS:**

- Plumbing connections must be made by a qualified service company who will comply with all available Federal, State, and Local Health, Plumbing and Safety codes.
- CMA recommends utilizing a water softening system to maintain water hardness measurements of 3.5 gpg (grains per gallon) or less. This will assure maximum results and optimum operation of the dishwasher.

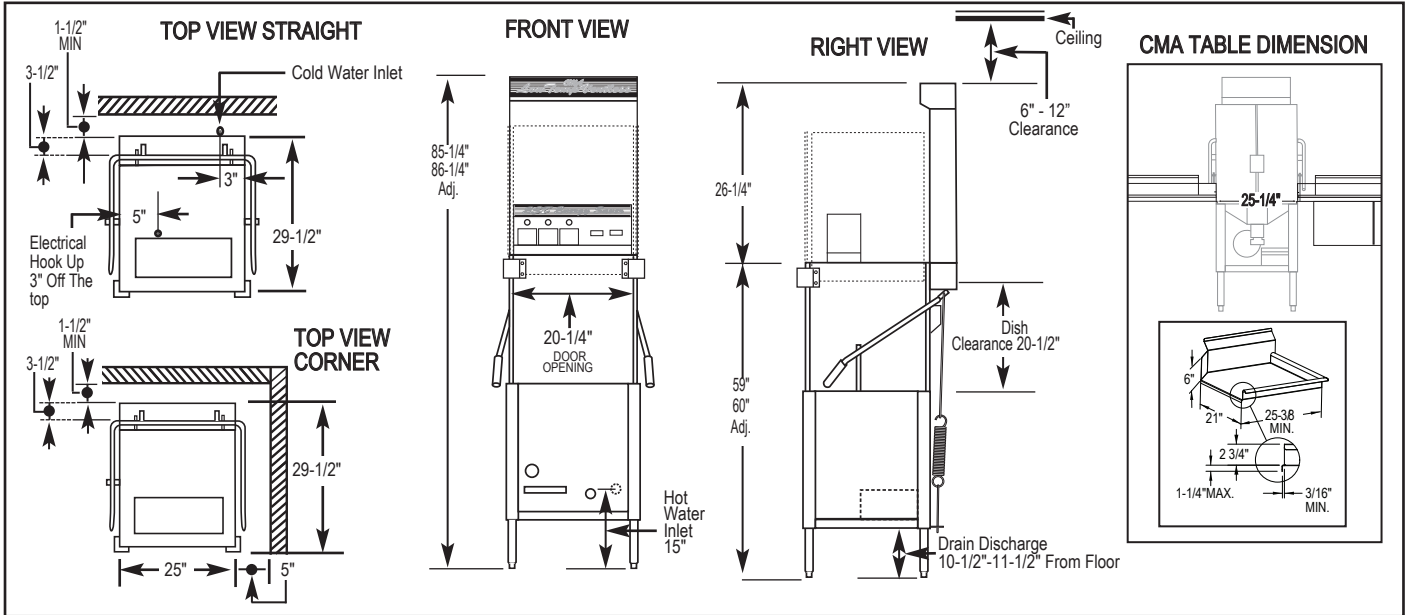

**Specifications:**

MODEL LOW TEMP EST-VENTLESS	USA	METRIC		USA	METRIC
<b>WATER CONSUMPTION</b>			<b>FRAME DIMENSIONS</b>		
PER RACK	1.09 GAL.	(4.12L)		DEPTH	29-1/2"
PER HOUR	33 GPH	(125 L)	WIDTH	25"	(64cm)
<b>OPERATING CYCLE</b>			HEIGHT	85-5/19"-86-5/16"	(216-217cm)
WASH TIME - SEC.	53	53	STANDARD TABLE HEIGHT	34"	(86cm)
RINSE TIME - SEC.	30	30	MINIMUM FAN CLEARANCE	6"	(15.2cm)
DWELL - SEC.	7	30	MAXIMUM CLEARANCE FOR DISHES	20-1/2"	(52cm)
VENT FAN	30	30	<b>STANDARD DISHRACK</b>		
TOTAL CYCLE	120	120	DIMENSIONS	1	1
<b>OPERATING CAPACITY</b>				20" x 20"	(50.8 X 50.8cm)
RACKS PER HOUR	30	30	<b>WASH PUMP MOTOR HP</b>	1	1
<b>WASH TANK CAPACITY</b>	1.09 GAL.	(4.12 L)	<b>ELECTRICAL RATING</b>	<b>VOLTS</b>	<b>AMPS</b>
<b>PUMP CAPACITY</b>	52 GPM	(197 LPM)	<b>DISHMACHINE</b>	115 (1 PHASE)	16
<b>WATER REQUIREMENTS</b>			<b>BOOSTER HEATER</b>	208/240 (3 PHASE)	25/29
COLD WATER	40-65°F	(5°C-18°C)		208/240 (1 PHASE)	43/50
HOT WATER	140°F	(60°C)	<b>SHIPPING WEIGHT</b>		
DRAIN CONNECTION	2"	(5.1cm)	APPROXIMATE	400#	(182 kg)
HOT WATER INLET	1/2"	(1.3cm)			
COLD WATER INLET	1/2"	(1.3cm)			
<b>OPERATING TEMPERATURE</b>					
REQUIRED	120°F	(49°C)			
RECOMMENDED	140°F	(60°C)			
<b>HEAT LOAD TO ROOM (BTU/HR)</b>					
	LATENT 5,900				
	SENSIBLE 2,400				

**Summary Specifications: Model LOW TEMP EST-VENTLESS**

The Energy Miser Model EST Ventless low temperature, chemical sanitizing commercial dishwasher, meets UL Electrical and ETL Sanitation (NSF Standard 3) standards. Model EST Low Temp Ventless is constructed of stainless steel. Each unit automatically washes, rinses and sanitizes food service utensils in standard 20" x 20" racks. Unit comes with upper and lower stainless steel wash arms.

**Advisory:** CMA does NOT endorse "Tankless On-Demand" water heaters for use on CMA Dishmachine products. CMA DOES endorse, and highly recommends, the standard "tank" style water heaters, sized properly to handle each particular facility with their water heating requirements.



CMA Dishmachines 12700 Knott Street, Garden Grove CA 92841 • 800-854-6417 • 714-898-8781 • Fax: 714-895-2141 • www.cmadishmachines.com

CMA reserves the right to modify specifications or discontinue models without prior notification.

© 7-2021 CMA, Inc.

an Ali Group Company



The Spirit of Excellence