

FRYERS**VULCAN****FRYMATE™
VX15 & VX21S**

Frymate VX15
shown with optional ThermoGlo™ Food Warmer

**SPECIFICATIONS**

Free standing or “Add-On” Frymate™, Vulcan-Hart Models: FRYMATE-VX15 and VX21S. These “Add-On” accessory Frymates can be securely attached to any gas or electric free-standing fryer or KleenScreen *PLUS*® fryer battery. “Add-On” a Frymate to the left or right side of a fryer, or both sides. 18 gauge steel body with stainless steel cabinet. Set of 4 casters (2 locking). Stainless steel sloped drain top with removable grease collector to allow for easy removal of food products, clean up and is dishwasher safe. Easy access storage area behind door. Grease strips, brackets, and hardware standard with every Frymate.

Overall Dimensions:

FRYMATEVX15 = 15½" w x 30⅜" d x 36¼" h working height.

FRYMATEVX21S = 21" w x 34⅜" d x 36¼" h working height.

NSF listed.

STANDARD FEATURES

- Stainless steel cabinet
- Set of 4 adjustable casters (2 locking)
- Stainless steel sloped drain top with removable grease collector
- One year limited parts and labor warranty

ACCESSORIES (Packaged & Sold Separately)

- Tank cover (works as solid top work surface)
 - **COVER-TANK:** FRYMATEVX15
 - **COVER-TANK85:** FRYMATE VX21S
- Food Warmer with 2 year warranty

COMPATIBILITY

- FRYMATEVX15:** All 35, 45 and 65 lb. fryers
- FRYMATEVX21S:** All 85 lb. fryers

VULCAN

a division of ITW Food Equipment Group LLC

P.O. Box 696 ■ Louisville, KY 40201 ■ Toll-free: 1-800-814-2028 ■ Local: 502-778-2791 ■ Quote & Order Fax: 1-800-444-0602



**FRYMATE™
VX15 & VX21S**

INSTALLATION INSTRUCTIONS

1. An adequate ventilation system is required for Commercial Cooking Equipment. Information may be obtained by writing to the National Fire Protection Association, Batterymarch Park, Quincy, MA 02269. When writing refer to NFPA No. 96.
2. This appliance is manufactured for commercial installation only and is not intended for home use.

SERVICE CONNECTIONS:

- ⓔ1 8', 120 volt power cord supplied on optional food warmer. NEMA 5-15P, 120/60/1, 9 amps electrical connection, 48¼" from floor.

NOTE: In line with its policy to continually improve its product, Vulcan reserves the right to change materials and specifications without notice.

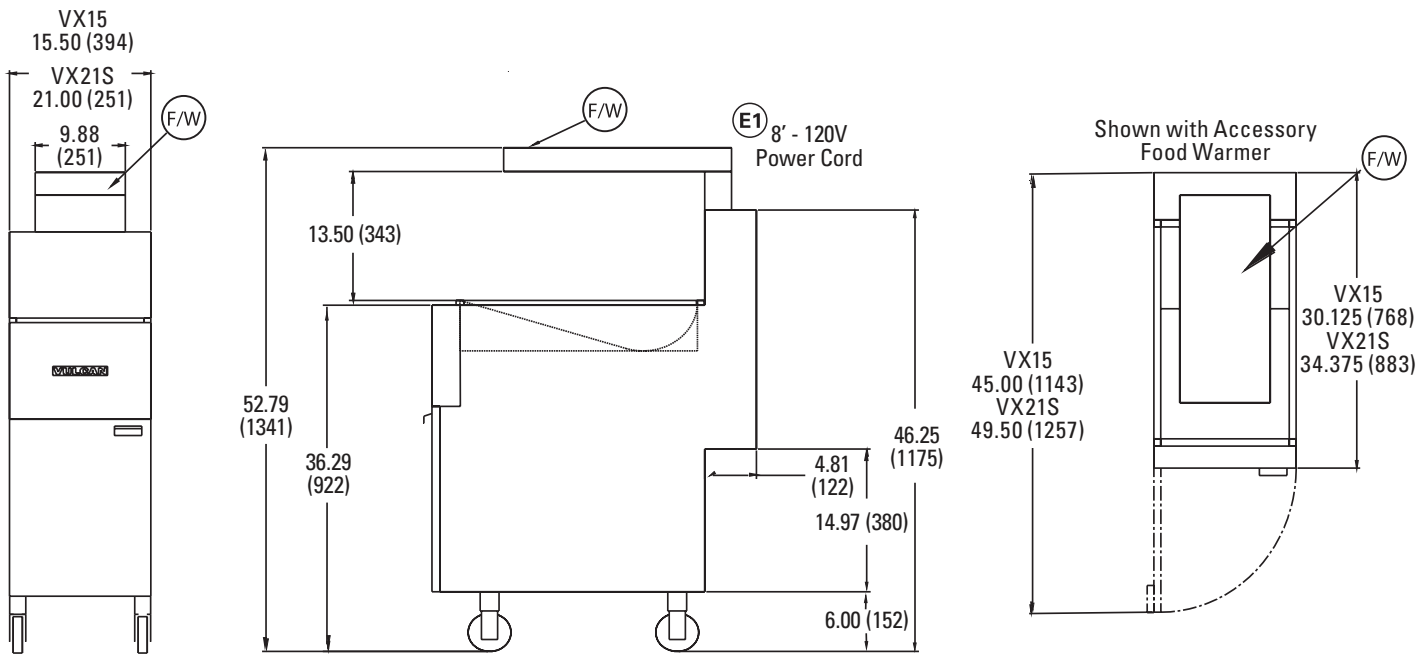

Model	Width	Depth	Overall Height	Working Height	Tank Size	BTU/HR	Fry Comp. Capacity	Approx. Shipping Weight
FRYMATEVX15	15.50"	30.125"	46.25"	36.25"	N/A	N/A	N/A	122 lbs. (55 kg)
FRYMATEVX21S	21.00"	34.375"	46.25"	36.25"	N/A	N/A	N/A	173 lbs. (78 kg)

This appliance is manufactured for commercial use only and is not intended for home use.



a division of ITW Food Equipment Group LLC

P.O. Box 696 ■ Louisville, KY 40201 ■ Toll-free: 1-800-814-2028 ■ Local: 502-778-2791 ■ Quote & Order Fax: 1-800-444-0602