



TRUE MANUFACTURING CO., INC.  
U.S.A. FOODSERVICE DIVISION

2001 East Terra Lane • O'Fallon, Missouri 63366-4434 • (636)240-2400  
Fax (636)272-2408 • Toll Free (800)325-6152 • Intl Fax# (001)636-272-7546  
Parts Dept. (800)424-TRUE • Parts Dept. Fax# (636)272-9471 • www.truemfg.com

Project Name: \_\_\_\_\_

Location: \_\_\_\_\_

Item #: \_\_\_\_\_ Qty: \_\_\_\_\_

Model #: \_\_\_\_\_

A/A #

S/S #

Model:

**GDIM-26NT-HC~TSL01**

## Glass Door Ice Merchandiser:

Swing Door No Tank Freezer with Hydrocarbon Refrigerant~True Standard Look Version 01



### GDIM-26NT-HC~TSL01

- ▶ The world's #1 manufacturer of glass door merchandisers.
- ▶ Designed using the highest quality materials and components to provide the user with an attractive, point of purchase ice merchandiser.
- ▶ High capacity, factory balanced refrigeration system, maintains 20°F to 25°F (-6.6°C to -3.8°C) cabinet temperature.
- ▶ Exterior - non-peel or chip black powder coated cold rolled steel; durable and permanent.
- ▶ Interior- attractive, white aluminum interior liner with stainless steel floor. Interior floor rack and backguard standard.
- ▶ Self closing door. Positive seal, torsion type closure system.
- ▶ Triple pane thermal insulated glass door assembly. Anti-fog film adhered to the glass pane to minimize condensation build up on glass for more effective merchandising
- ▶ LED interior lighting provides more even lighting throughout the cabinet. Safety shielded.
- ▶ Entire cabinet structure is foamed-in-place using a high density, polyurethane insulation that has zero ozone depletion potential (ODP) and zero global warming potential (GWP).
- ▶ Holds (54) 8 lbs. (4 kg) bags of ice.

## ROUGH-IN DATA

Specifications subject to change without notice.  
Chart dimensions rounded up to the nearest 1/8" (millimeters rounded up to next whole number).

Model	Doors	Floor Racks	Cabinet Dimensions (inches) (mm)			HP	Voltage	Amps	NEMA Config.	Cord Length (total ft.) (total m)	Crated Weight (lbs.) (kg)
			W	D†	H						
GDIM-26NT-HC~TSL01	1	1	30 762	29 7/8 759	78 5/8 1998	1/3 N/A	115/60/1	6.0 N/A	5-15P	9 2.74	TBD TBD

† Depth does not include 1 3/8" (42 mm) for door handles.



APPROVALS:

AVAILABLE AT:

Model:  
**GDIM-26NT-HC~TSL01**

**Glass Door Ice Merchandiser:**  
*Swing Door No Tank Freezer with Hydrocarbon Refrigerant~True Standard Look Version 01*



**STANDARD FEATURES**

**DESIGN**

- True's commitment to using the highest quality materials and over sized refrigeration systems provides the user with colder product temperatures, and lower utility costs in an attractive ice merchandiser

**REFRIGERATION SYSTEM**

- Factory engineered, self-contained, capillary tube system using environmentally friendly R290 hydrocarbon refrigerant that has zero (0) ozone depletion potential (ODP), & 0.02 global warming potential (GWP).
- High capacity, factory balanced refrigeration system, maintains 20°F to 25°F (-6.6°C to -3.8°C) cabinet temperature.
- State of the art, electronically commutated evaporator and condenser fan motors. ECM motors operate at higher peak efficiencies and move a more consistent volume of air which produces less heat, reduces energy consumption and provides greater motor reliability.
- Bottom mounted condensing unit positioned for easy maintenance; "No stoop" design maximizes visibility by raising merchandised product to higher level.
- Automatic defrost system time-initiated, temperature-terminated. Saves energy consumption and provides shortest possible defrost cycle.

**CABINET CONSTRUCTION**

- Exterior - non-peel or chip black powder coated cold rolled steel; durable and permanent.
- Interior - attractive, white aluminum interior liner with stainless steel floor.
- Insulation - entire cabinet structure is foamed-in-place using a high density, polyurethane insulation that has zero ozone depletion potential (ODP) and zero global warming potential (GWP).
- Welded, heavy duty steel frame rail, black powder coated for corrosion protection.
- Frame rail fitted with leg levelers.
- Illuminated exterior sign panel.

**DOOR**

- Triple pane thermal insulated glass door assembly. Anti-fog film adhered to the glass pane to minimize condensation build up on glass for more effective merchandising
- Door fitted with a 12" (305 mm) long extruded handle.
- Self closing door. Positive seal, torsion type closure system.
- Magnetic door gasket of one piece construction, removable without tools for ease of cleaning.
- Full-length door designed to match the appearance of our other glass door merchandising products.

**STORAGE CAPACITY**

- Interior floor rack and backguard prevents bags of ice from blocking optimal airflow.
- Holds (54) 8 lbs. (4 kg) bags of ice.

**LIGHTING**

- LED interior lighting provides more even lighting throughout the cabinet. Safety shielded.

**MODEL FEATURES**

- Evaporator is epoxy coated to eliminate the potential of corrosion.
- Listed under NSF/ANSI Standard 7 for the storage and/or display of packaged or bottled product.

**ELECTRICAL**

- Unit completely pre-wired at factory and ready for final connection to a 115/60/1 phase, 15 amp dedicated outlet. Cord and plug set included.



115/60/1  
NEMA-5-15R

**OPTIONAL FEATURES/ACCESSORIES**

Upcharge and lead times may apply.

- Black exterior.
- Stainless steel exterior.
- Black aluminum interior liner.
- Stainless steel interior liner with gray shelving, back and floor guards.
- 6" (153 mm) standard legs.
- 6" (153 mm) seismic/flanged legs.
- 2 1/2" (64 mm) diameter castors.
- 4" (102 mm) diameter castors.

**PLAN VIEW**

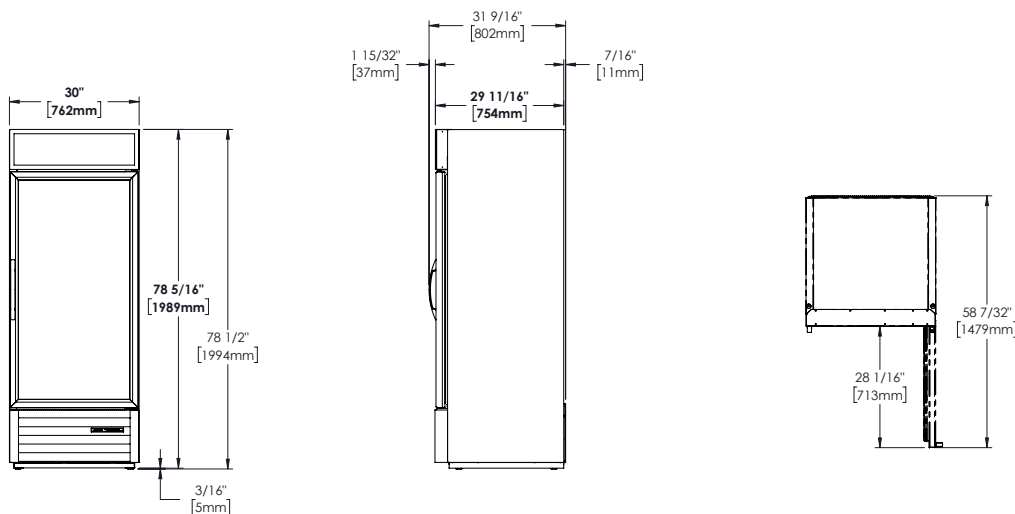

METRIC DIMENSIONS ROUNDED UP TO THE NEAREST WHOLE MILLIMETER

SPECIFICATIONS SUBJECT TO CHANGE WITHOUT NOTICE



Model	Elevation	Right	Plan	3D	Back
GDIM-26NT-HC-TSL01					

**TRUE MANUFACTURING CO., INC.**