

QuietQube[®] iF600C Remote Ice Cube Machine

Air-Cooled Ice Cube Machine with Patented CVD Technology[®]

Models

IYF0600C



IYF0600C Ice Cube Machine - 115V

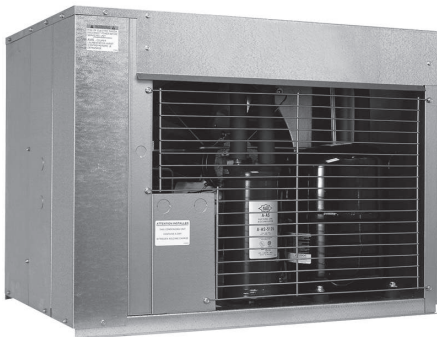

CVD Condensing Unit - 230V



IY0600C
Ice Machine
on a D-570 bin

Standard Features

QuietQube Series Remote System consists of a remote condensing unit, interconnecting refrigerant lines, ice machine head section along with an ice storage bin, countertop dispenser, or floor dispenser. All ordered separately. QuietQube ice machine with CVD condensing unit is designed as a Manitowoc system and cannot be used with any other ice machine or remote condenser brand.

- **ENERGY STAR** - the iF600Cs exceed ENERGY STAR[®] standards and targets future energy efficiency standards.
- **Space-Saving Design** - Up to 634 lbs. (288 kgs) daily ice production and only 30" (76.20 cm) wide.
- **easyTouch[®] Display**- New icon based touch screen takes the guess work out of owning and operating an ice machine.
- **Programmable Ice Production** - Now its super easy to program your ice machine to be off at certain times of the day to save money with fluctuating electrical rates. Also programmable by daily ice production volume.
- **Easy to Clean Foodzone** - Hinged front door swings out for easy access. Removable water-trough, distribution tube, curtain, and sensing probes for fast and efficient cleaning. Select components made with AlphaSan[®] antimicrobial.
- **Intelligent Diagnostics** - provide 24 hour preventative maintenance and diagnostic feedback for trouble free operation.
- **Acoustical Ice Sensing Probe** - Unique patented technology allows for reliable operation in challenging water conditions and environments.
- **DuraTech[™] Exterior** - provides superior corrosion resistant above stainless steel. Innovative clear-coat resists fingerprints and dirt making it easier to keep clean.
- **Available LuminIce II Growth Inhibitor**- Controls the growth of bacteria and yeast with the food zone keep the machine cleaner longer. A new indicator in the display keeps you abreast of the operational status.

COMMERCIAL WARRANTY		
ICE MAKER	EVAPORATOR	COMPRESSOR
3	5	5
YEAR	YEAR	YEAR PARTS
PARTS AND LABOR		3 YEAR LABOR

Ice Shape

Half Dice
 $\frac{3}{8}$ " x $1\frac{1}{8}$ " x $\frac{7}{8}$ "
 (.95 x 2.86 x 2.22 cm)

QuietQube[®] iF600C Remote Ice Cube Machine



COMPANY WITH
QUALITY SYSTEM
CERTIFIED BY DNV
= ISO 9001:2008 =



iF0600C Ice Machine

- (A) Electrical Entrance (2) Options
- (B) Suction Refrigerant Shut-off Valve
- (C) Liquid Refrigerant Shut-off Valve
- (D) 3/8" (0.95 cm) F.P.T. Ice Making Water Inlet
- (E) 1/2" (1.27 cm) F.P.T. Ice Making Water Drain

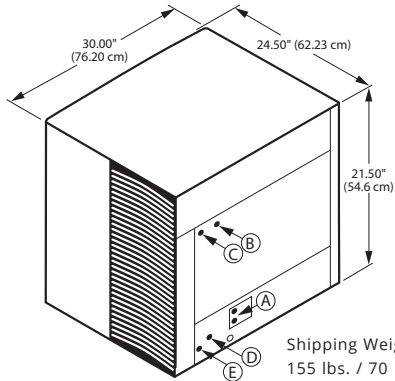

Installation Note
 Minimum installation clearance:
 Top: 5" (13 cm)
 Back: 5" (13 cm)
 Sides: 5" (13 cm)

Shipping Weight:
 155 lbs. / 70 kg

CDF0600_A Remote Condensing Unit

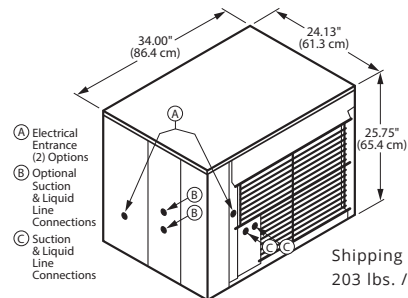

Shipping Weight:
 203 lbs. / 92 kgs

Ice Machine Electric

115/60/1 standard.
 (230/50/1 also available, consult factory.)

Total Amps: 1.1
Max. fuse size: 15 amps
 HACR-type circuit breakers can be used in place of fuses.

Specifications

Operating Limits:
 Ambient Temperature Range:
 40° to 110° F (4.4° to 43.4° C)

Water Temperature Range:
 40° to 90° F (4.4° to 32.2° C)

Water Pressure Ice Maker Water In:
 Min. 20 psi (137.9 kPa)
 Max. 80 psi (551.1 kPa)

iAuCS® Accessory

Automatic Cleaning System purchased as an option and installed in the field.



Condensing Unit Electric

208-230/60/1 standard. 208-230/60/3 and 230/50/1 also available. 50 Hz version of this model meets the international standard, IEC335-1, requirements for "tropical rating," the most severe duty rating an ice machine can obtain, (consult factory). HACR-type circuit breakers can be used in place of fuses. Note: QuietQube ice machine power supply is wired independent of CVD condensing unit.

Min. circuit ampacity: 9.0 1ph 6.6 3ph
Max. fuse size: 15 amps 1ph 15 amps 3ph
 HACR-type circuit breakers can be used in place of fuses.

BTU Per Hour: 11,800 (average) 13,700 (peak)

Compressor: Nominal rating: 1 HP

Operating Limits:
 Ambient Temperature Range:
 -20° to 120° F (-29° to 49° C)

Installation Information and Dimensions:

- Maximum Line Length
 —100' (30.5 m).*
- Maximum Vertical Rise*
 —35' (10.7 m) above ice machine.
- Maximum Vertical Drop
 —15' (4.5 m) below ice machine.
- Minimum Installation Clearance
 —Top/sides: 0" (0 cm)
 —Back/Front: 48" (122 cm).

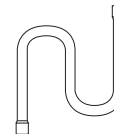

*A rise over 20' (6 m) requires S-Trap Kit K-00172 - ordered separately.

Remote Air-cooled Ice Machine

Model	Ice Shape	Ice Production 24 Hours		Power kWh/100 lbs. @90°Air/70°F*
		70°Air/50°F Water 21° Air/10°C Water	90°Air/70°F Water* 32° Air/21°C Water	
iYF0600C	half-dice	600 lbs.	530 lbs.	5.53
		272 kg	240 kgs	
Water usage/100 lbs./45.4 kgs of Ice				
Potable Water: 20 gallons, 75.7 liters				

Ice machine for use with ice storage bin or ice dispenser and CVD condensing unit all ordered separately.

*kWh per 100 lbs. is total power of ice machine and condensing unit. Ice machine is 1 ph only. Condensing unit is 1 ph or 3 ph.

Indigo NXT Remote Tubing Kits

Model	Line Length		Weight	
	ft.	m	lbs.	kg
RC-21	20	6	12	5
RC-31	30	9	17	9
RC-51	50	15	27	13

Welbilt reserves the right to make changes to the design or specifications without prior notice.