

**WARING**

# MX1200XTS

## XPREP® Hi-Power Variable-Speed Food Blender with 64 oz. Stainless Steel Container



\*Made in USA with US and foreign parts.

### ELECTRICAL

Voltage: 120 V

Frequency: 60Hz

Watts: 1560 W

Amps: 12.5 A

Plug Type: NEMA 5-15P

Cord Length: 6 feet



### MAIN FEATURES

- Heavy-duty, high-performance 3½ peak HP motor with variable-speed selection is the strongest in its class. It powers through the toughest ice and frozen fruit mixtures in seconds.
- Super-high 30,000+ RPM motor speed for the smoothest consistencies.
- Simple ON/Standby and Variable/PULSE paddle switches with variable-speed knob are easy to use and easy to find in a dimly lit location.
- Variable-speed control from 1,500 RPM to 20,000 RPM for maximum control over your blending — perfect for all types of food preparation.
  - Unbreakable, dishwasher-safe, 64 oz., stainless steel container has a cloverleaf jar design to create a high-power vortex, funneling food directly into the blade.
- High-performance, high-impact stainless steel blade is user replaceable for easy servicing.
- Easily removable container cover with removable clear cap for adding ingredients and pressure reduction during hot food blending.
- User-replaceable, metal-on-metal stainless steel coupling system between base and container for durability and reliability.
- One-piece, dishwasher-safe, removable jar pad.
- Optional sound enclosure easily retrofits to base for noise reduction.
- Recommended for 75+ cycles per day.
- Limited Three-Year Motor and Two-Year Parts & Labor Warranty.

### SALES FEATURES

This heavy-duty 3½ peak HP blender teams up with our stainless steel jar/blade assembly for maximum power and efficiency. It's ferocious enough for everything from smoothies and frozen drinks to thick spreads, desserts, dressings, and all types of food preparation. Rev it up with variable-speed controls from 1,500 to 20,000 RPM and a max pulse of 30,000+ RPM. Perfect for a busy bar, health facility, school or coffee shop.

XPREP® Hi-Power Variable-Speed Food Blender with 64 oz. Stainless Steel Container

MX1200XTS



@waringproducts

©2025 Waring

314 Ella T. Grasso Avenue, Torrington, CT 06790



Tel. 800-492-7464 • Fax 860-496-9008

waring.com



# XPREP® Hi-Power Variable-Speed Food Blender with 64 oz. Stainless Steel Container MX1200XTS

## PARTS & ACCESSORIES

- |   |   |   |  |
|---|---|---|--|
|    | <b>CAC90</b><br>64-oz. Stainless Steel Container  |    | <b>CAC95-12</b><br>64-oz. Green Copolyester Container                      |
|    | <b>CAC93X</b><br>48-oz. Copolyester Container   |    | <b>CAC95-28</b><br>64-oz. Orange Copolyester Container                     |
|    | <b>CAC93X-03</b><br>48-oz. Yellow Copolyester Container   |    | <b>CAC116</b><br>Blending Assembly Kit and Retainer Ring Kit               |
|    | <b>CAC93X-06</b><br>48-oz. Blue Copolyester Container   |    | <b>CAC119</b><br>Retainer Ring Wrench                                      |
|    | <b>CAC93X-10</b><br>48-oz. Purple Copolyester Container   |    | <b>CAC158</b><br>Blending Assembly Kit                                     |
|    | <b>CAC93X-12</b><br>48-oz. Green Copolyester Container  |    | <b>CAC159</b><br>Retainer Ring Kit   |
|   | <b>CAC93X-28</b><br>48-oz. Orange Copolyester Container   |   | <b>CAC182</b><br>Drive Coupling  |
|  | <b>CAC95</b><br>The Raptor™ – Aggressive, All-Purpose, Stackable, 64-oz. BPA-Free Copolyester Container |  | <b>CAC183</b><br>Drive Coupling with Square Drive                          |
|  | <b>CAC95-03</b><br>64-oz. Yellow Copolyester Container  |  | <b>CAC161</b><br>Drive Coupling Removal Tool                               |
|  | <b>CAC95-06</b><br>64-oz. Blue Copolyester Container  |  | <b>CAC169</b><br>Spatula – Custom designed for use with MX Series Blenders |
|  | <b>CAC95-10</b><br>64-oz. Purple Copolyester Container  |  | <b>SE1500</b><br>Sound Enclosure   |

## DIMENSIONS

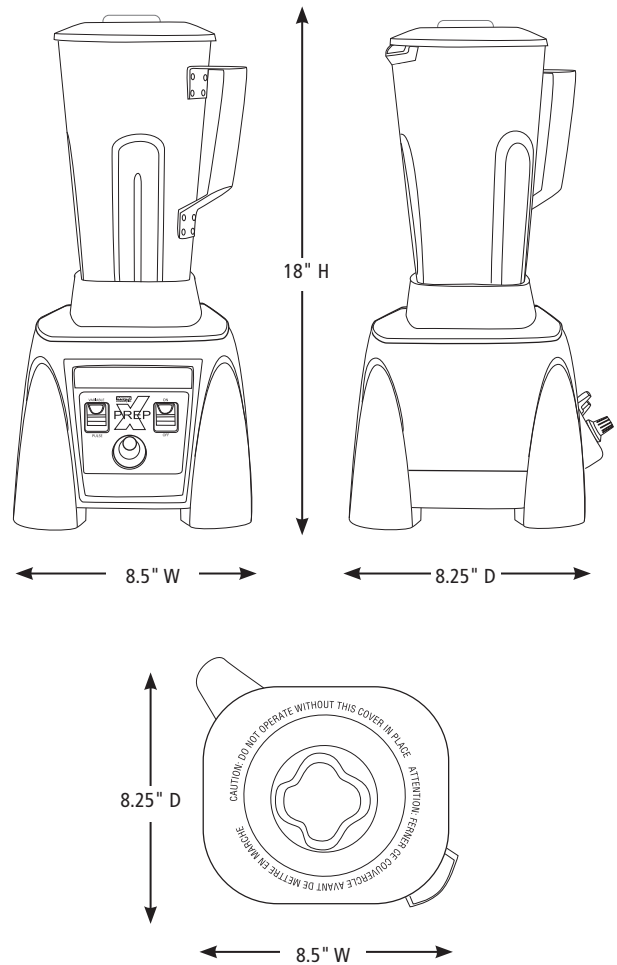

Out-of-Box Weight: 15.66 lb.

ORDERING INFORMATION	#STD. PKG.	GIFTBOX WEIGHT	CUBIC FEET	BOX DIMENSIONS D X W X H	UPC	CASE PKG.	MC WEIGHT	MC DIMENSIONS D X W X H	MBC
MX1200XTS– XPREP® Hi-Power Variable – Speed Food Blender with 64 oz. Stainless Steel Container	1	18.5 lb.	1.05	11.375" x 10.375" x 15.375"	040072006920	1	20 lb.	11.75" x 10.75" x 16.25"	10040072006927



@waringproducts

©2025 Waring Commercial  
314 Ella T. Grasso Avenue, Torrington, CT 06790  
Tel. 800-492-7464 • Fax 860-496-9008

waring.com

25WC95379 / REV 05/25