

REFRIGERATOR MANUFACTURER
Turbo air
 more durable, efficient, beautiful

4184 E. Conant St.
 Long Beach, CA 90808
 Tel. 310-900-1000
 Fax. 310-900-1077
www.turboairinc.com

Project :	
Model # :	
Item # :	Qty :
Available W/H :	
Approval :	

Direct Cooling Type Deli Cases

Bakery & Deli Cases
 High Profile

Patented Self-Cleaning Condenser

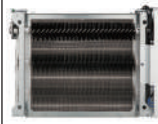

This product is equipped with a fine mesh filter to the front of the condenser to catch dust, and a rotating brush that moves up and down daily to remove excess buildup outward and away.

Model : TCDD-72H-W(B)-N



* White and black color come standard



≡ FEATURES & BENEFITS ≡

- Self-Cleaning Condenser**
 The accumulation of dust in the condenser can cause the failure or breakdown of refrigerators. Refrigerators run normally until they reach a certain level of accumulation. At some point, when they are over the limit, their performance drops quickly resulting in damage to, or disposal of the stored products inside. The Self-Cleaning Condenser device keeps the condenser clean and prevents system failure by automatically brushing daily.
- Hydrocarbon refrigerants (R-290)**
 With innovative and eco-friendly technology, Turbo Air brings you hydrocarbon refrigerators designed to meet DOE's Energy Conservation Standards in 2017 and to use EPA's SNAP Program approved HC refrigerants. Hydrocarbon refrigerants do not deplete the ozone layer and have very low contribution to global warming (ODP-0, GWP-3).
- Attractive, elegant, glass sided Euro design**
 Curved tempered front glass and minimal frame provide full product visibility to optimize display effects. Its elegant contemporary euro design will not only enhance any store atmosphere but also will keep product presentation at its best and most beautiful.
- High-density polyurethane insulation**
 The entire cabinet structure is foamed-in-place using high density, CFC free polyurethane insulation.
- Low-E coated double pane glass is tempered for safety**
- Easy access control panel**
- Sliding rear doors for product loading & unloading**
- Heavy duty, white PE coated wire shelves**
- Cantilever wired shelves adjustable up and down, tilted**
- Stainless steel floor and airflow grille**
- Rear access to compressor compartment for quick and easy service**
- Refrigerated deli case holds avg. 33°F ~ 41°F for fresher products**



Model	CU./FT.	# of Shelves	HP	AMPS	Crated Weight (lbs.)	L x D x H (inches)
TCDD-72H-W(B)-N	24.7	2	3/4	7.8	777	72 1/2 x 30 x 50 1/8

Direct Cooling Type Deli Cases

Bakery & Deli Cases
High Profile

Model : TCDD-72H-W(B)-N

ELECTRICAL DATA	
Voltage	115/60/1
Plug Type	☺ NEMA 5-15P
Full Load Amperes	7.8
Compressor HP	3/4
Refrigerant	R-290
DIMENSIONAL DATA	
Net Capacity (cu. ft.)	24.7
Ext. Length Overall (in.)	72 1/2 (1842mm)
Ext. Depth Overall (in.)	30 (762mm)
Ext. Height Overall (in.)	50 1/8 (1273mm)
Int. Length Overall (in.)	69 1/4 (1757mm)
Int. Depth Overall (in.)	24 (610mm)
Int. Height Overall (in.)	23 5/8 (599mm)
Shelf Size (in.)	68 1/4 x 15 3/4
	68 1/4 x 17 3/4
# of Shelves	2
Power Cord Length (in.)	59 1/8
Net Weight (lbs.)	639
Gross Weight (lbs.)	777

Design and specifications subject to change without notice.
Actual shipping weight may differ due to extra packing materials for product protection.

■ **WARRANTY :** 2 Year Parts and Labor Warranty
Additional 3 Year Warranty on Compressor

■ STANDARD FEATURES

- Anti-corrosion coated evaporator
- Self-contained system, no plumbing required
- Safety shielded LED interior lighting
- Solar powered digital thermometer
- Digital electronic thermostat with defrost control
- White and black colors come standard

- Recommended operating conditions

TCDD models are designed to operate in an environment where temperature & humidity do not exceed 75°F and 55% respectively. Units should not be installed near HVAC vents, fans or doorways that will disrupt the air curtain and compromise the function of the cabinet. Air curtain models will run most efficiently when completely loaded with product.

PLAN VIEW

(unit : inch)

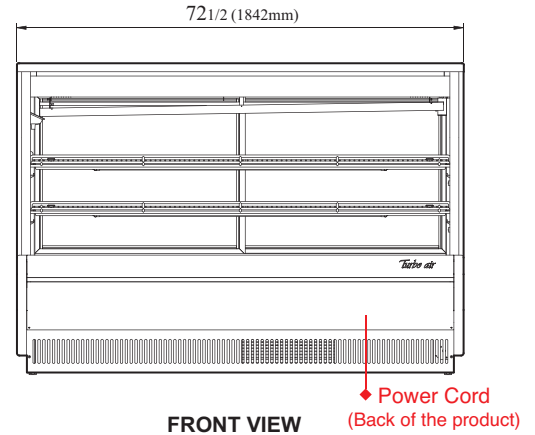

FRONT VIEW

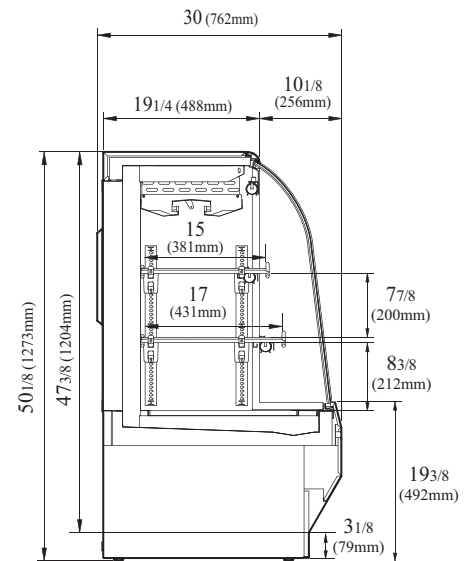

SIDE VIEW

Ver.20190412



■ Turbo Air : 800-627-0032 ■ GK : 800-500-3519
■ Warranty : 800-381-7770 ■ AC : 888-900-1002

REFRIGERATOR MANUFACTURER
Turbo air

GERMAN
KNIFE

||| **RADIANCE**

ROBINATION SYSTEM
Turbo air

TEXAKING