



Project _____

Item # _____

Quantity _____

Toast-Qwik® Electric Conveyor Toasters

Models: TQ-800, -800H, -805, -800BA, -800HBA, -1800, -1800H, -1800BA, -1800HBA

The Hatco Toast-Qwik® is an economical conveyor toaster with fast, dependable and versatile toasting, offering 800 to 1800 slices per hour. Hatco toasters utilize conveyor speed, not temperature to determine toasting color. This method allows for instant adjustment of toasting time to match the bread product being toasted.

Standard features

- Hatco's ColorGuard sensing system assures toast uniformity
- Optional power save mode with indicator light saves energy and money during slow periods
- Efficient design of front or rear discharge allows Toast-Qwik to be placed where it is most convenient – for sending product to operator side or customer/server
- BA models toast one side only and are for bagels and buns only, cut side up
- Opening height is 2" (51 mm) and for H models is 3" (76 mm)
- All models are constructed with stainless steel and powdercoated / black lower side covers
- Insulation and an interior fan provide cool surface temperatures
- Toast storage area keeps bread warm and dry
- Permanently lubricated ball bearing motor and heating elements guaranteed against burnout and breakage for two years



Options (available at time of purchase only)

- Automatic Power Save Mode

Accessories

- Additional Extended Feed Guide (Add 3" [76 mm]) (not available for the TQ-1800 series)
- Security Package (not available for the TQ-1800 series)

 IFS anti-microbial coatings use naturally-occurring, environmentally sustainable, silver ions to help inhibit the growth of microbes on the powder coated surface. See www.hatcocorp.com/antimicrobial-paint for more information.

 For operation, location and safety information, please refer to the Installation and Operating Manual.



TQ-800 series only

HATCO CORPORATION | P.O. Box 340500 Milwaukee, WI 53234-0500 U.S.A. | (414) 671-6350



www.hatcocorp.com | support@hatcocorp.com | [Find a Hatco Rep](#) | [Image Library](#) | [Document Library](#) | [Patents](#) | [Chat](#)



Toast-Qwik® Electric Conveyor Toasters

Models: TQ-800, -800H, -805, -800BA, -800HBA, -1800, -1800H, -1800BA, -1800HBA

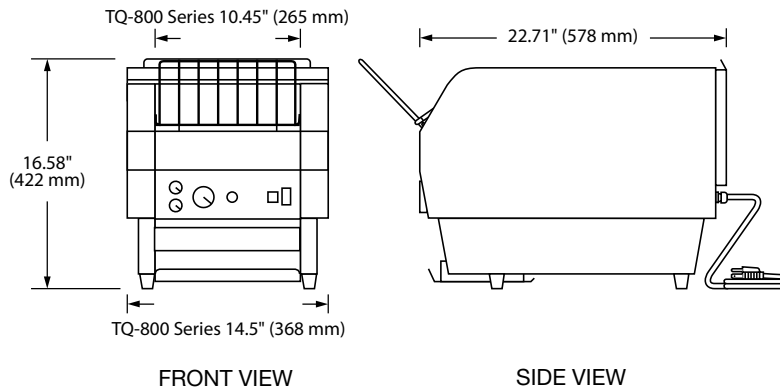

SPECIFICATIONS Toast-Qwik® Conveyor Toasters

The shaded areas contain electrical information for International models

Model	Dimensions (W x D x H)	Volts (Single Phase)	Hertz	Watts	Amps	Capacity per Minute	Plug	Approx. Ship Weight	
TQ-800 TQ-800H	14.5" x 22.71" x 16.58" (368 x 578 x 422 mm) Tray extends 6.5" (165 mm) in rear	208	60	3330	16.0	14 slices	NEMA 6-20P †	62 lbs. (28 kg)	
		240			13.9	14 slices	NEMA 6-15P*		
		200	50/60	3050	15.3	14 slices	AS 3112		
		220-230 (CE)			3019-3300		13.7-14.4		CCC or No Plug
TQ-805		230-240 (CE)	3300-3593	14.4-15.0	14 slices	No Plug	62 lbs. (28 kg)		
			50/60	3300-3593		14.4-15.0	14 slices	No Plug	62 lbs. (28 kg)
TQ-800BA TQ-800HBA			208	60	3280	15.8	14 slices	NEMA 6-20P †	62 lbs. (28 kg)
			240			13.7		NEMA 6-15P*	
	200		50/60	3003	15.0	14 slices	AS 3112		
	220-230 (CE)				2791-3050		12.7-13.3	CCC or No Plug	
	230-240 (CE)				3050-3321		13.3-13.9	No Plug	

† Available with optional 6-30P cord.
* Canadian models use NEMA 6-20P.





Toast-Qwik® Electric Conveyor Toasters

Models: TQ-800, -800H, -805, -800BA, -800HBA, -1800, -1800H, -1800BA, -1800HBA

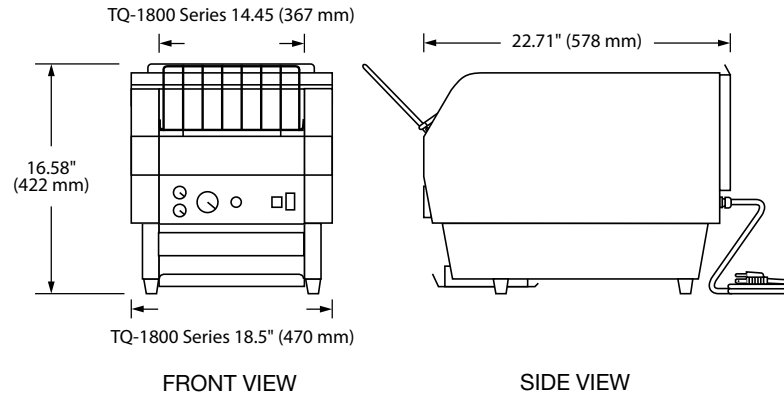

SPECIFICATIONS Toast-Qwik® Conveyor Toasters

The shaded areas contain electrical information for International models

Model	Dimensions (W x D x H)	Volts (Single Phase)	Hertz	Watts	Amps	Capacity per Minute	Plug	Approx. Ship Weight
TQ-1800	18.5" x 22.71" x 16.58" (470 x 577 x 421 mm) Tray extends 6.5" (165 mm) in rear	208	60	4440	21.4	30 slices	NEMA 6-30P	73 lbs. (33 kg)
		240	60	4440	18.5	30 slices	NEMA 6-30P	
		220	60	3731	17.0	30 slices	BS-1363 or No Plug	
		220-230 (CE)	50/60	3731-4078	17.0-17.7	30 slices	CCC or No Plug	
		230-240 (CE)		4078-4440	17.7-18.5			
TQ-1800H		208	60	4650	22.4	30 slices	NEMA 6-30P	73 lbs. (33 kg)
		240			19.4			
		200	60	4271	21.4	30 slices	BS-1363 or No Plug	
		220	60	3907	17.8	30 slices	BS-1363 or No Plug	
		220-230 (CE)	50/60	3907-4271	17.8-18.6	30 slices	CCC or No Plug	
TQ-1800BA	208	60	4580	22.0	30 slices	NEMA 6-30P	73 lbs. (33 kg)	
	240			19.1				
	220-230 (CE)	50/60	3849-4206	17.5-18.3	30 slices	CCC or No Plug		
	230-240 (CE)		4206-4580	18.3-19.1				
TQ-1800HBA	208	60	4580	22.0	30 slices	NEMA 6-30P	73 lbs. (33 kg)	
	240			19.1				
	220-230 (CE)	50/60	3849-4206	17.5-18.3	30 slices	CCC or No Plug		
	230-240 (CE)		4206-4580	18.3-19.1				

PLUG CONFIGURATIONS

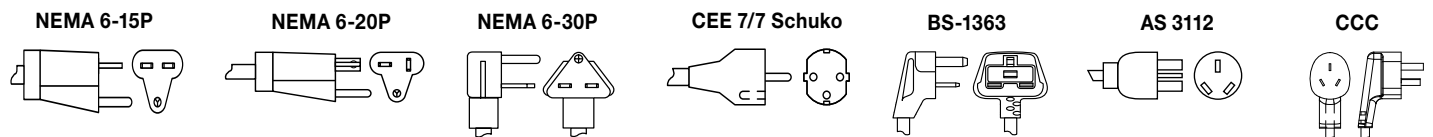

PRODUCT SPECS Conveyor Toasters

The electric Toast-Qwik® Conveyor Toaster with ColorGuard sensing system shall be a Hatco model ... as manufactured by the Hatco Corporation, Milwaukee, WI 53234 U.S.A.

The Toaster shall have the capacity to toast up to ... pieces per minute and it shall be rated at ... kW, ... volts, single phase. The toaster shall be of stainless steel design and

shall include a front mounted controlpanel with a toast selector knob, variable speed control knob, and an aluminum toast collector pan. The toaster will have multiple metal sheathed heating elements and an impedance protected motor. It shall be complete with factory attached UL listed 4' (1219 mm) cord and plug.

Warranty consists of 24/7 parts and service assistance (U.S. and Canada only).

HATCO CORPORATION | P.O. Box 340500 Milwaukee, WI 53234-0500 U.S.A. | (414) 671-6350



www.hatcocorp.com | support@hatcocorp.com | [Find a Hatco Rep](#) | [Image Library](#) | [Document Library](#) | [Patents](#) | [Chat](#)