



TRUE MANUFACTURING CO., INC.
U.S.A. FOODSERVICE DIVISION

2001 East Terra Lane • O'Fallon, Missouri 63366-4434 • (636)240-2400
Fax (636)272-2408 • Toll Free (800)325-6152 • Intl Fax# (001)636-272-7546
Parts Dept. (800)424-TRUE • Parts Dept. Fax# (636)272-9471 • www.truemfg.com

Project Name: _____

Location: _____

Item #: _____ Qty: _____

Model #: _____

A/A #

S/S #

Model:
TWT-60-32F-HC

Deep Worktop:
Solid Door Freezer with Hydrocarbon Refrigerant



TWT-60-32F-HC

- ▶ True's deep worktop units are designed with enduring quality that protects your long term investment. True's deep worktop units features the combined advantage of convenient worktop prep space with deeper refrigerated storage.
- ▶ Designed using the highest quality materials and components to provide the user with colder product temperatures, lower utility costs, exceptional food safety and the best value in today's food service marketplace.
- ▶ Extra large evaporator coil balanced with higher horsepower compressor and large condenser maintains -10°F (-23.3°C). Ideally suited for both frozen foods and ice cream.
- ▶ Factory engineered, self-contained, capillary tube system using environmentally friendly R290 hydro carbon refrigerant that has zero (0) ozone depletion potential (ODP), & 0.02 global warming potential (GWP).
- ▶ All stainless steel front, top and ends. Corrosion resistant GalFan coated steel back. Top and backsplash are one piece formed construction. Bacteria and food particles cannot be trapped underneath as with other two-piece worktop units.
- ▶ Interior - attractive, clear coated aluminum liner. Stainless steel floor with coved corners.
- ▶ Heavy duty PVC coated wire shelves.
- ▶ Foamed-in-place using a high density, polyurethane insulation that has zero ozone depletion potential (ODP) and zero global warming potential (GWP).
- ▶ Automatic defrost system time-initiated, time-terminated.

ROUGH-IN DATA

Specifications subject to change without notice.
Chart dimensions rounded up to the nearest 1/8" (millimeters rounded up to next whole number).

Model	Doors	Shelves	Cabinet Dimensions (inches) (mm)			HP	Voltage	Amps	NEMA Config.	Cord Length (total ft.) (total m)	Crated Weight (lbs.) (kg)
			W	D†	H*						
TWT-60-32F-HC	2	4	60 1/4 1531	32 3/8 823	33 3/8 848	1/2 N/A	115/60/1	5.8 N/A	5-15P	7 2.13	385 175

† Depth does not include 1" (26 mm) for rear bumpers and 1/4" (7 mm) for front bumper.

* Height does not include 6 1/4" (159 mm) for castors or 6" (153 mm) for optional legs.



APPROVALS:

AVAILABLE AT:

Model:
TWT-60-32F-HC

Deep Worktop: Solid Door Freezer with Hydrocarbon Refrigerant



STANDARD FEATURES

DESIGN

- True's commitment to using the highest quality materials and oversized refrigeration systems provides the user with colder product temperatures, lower utility costs, exceptional food safety and the best value in today's food service marketplace.

REFRIGERATION SYSTEM

- Factory engineered, self-contained, capillary tube system using environmentally friendly R290 hydro carbon refrigerant that has zero (0) ozone depletion potential (ODP), & 0.02 global warming potential (GWP).
- Energy efficient, factory balanced refrigeration system with guided airflow to provide uniform product temperatures.
- Extra large evaporator coil balanced with higher horsepower compressor and large condenser; maintains -10°F (-23.3°C). Ideally suited for both frozen foods and ice cream.
- State of the art, electronically commutated evaporator and condenser fan motors. ECM motors operate at higher peak efficiencies and move a more consistent volume of air which produces less heat, reduces energy consumption and provides greater motor reliability.
- Condensing unit access in back of cabinet, slides out for easy maintenance.
- Automatic defrost system time-initiated, time-terminated.

CABINET CONSTRUCTION

- All stainless steel front, top and ends. Corrosion resistant GalFan coated steel back. Top and backsplash are one piece formed construction. Bacteria and food particles cannot be trapped underneath as with other two-piece worktop units.

- Interior - attractive, clear coated aluminum liner. Stainless steel floor with coved corners.
- Insulation - entire cabinet structure and solid doors are foamed-in-place using a high density, polyurethane insulation that has zero ozone depletion potential (ODP) and zero global warming potential (GWP).
- 5" (127 mm) diameter stem castors - locks provided on front set. 36" (915 mm) work surface height.

DOORS

- Stainless steel exterior with clear aluminum liner to match cabinet interior.
- Each door fitted with 12" (305 mm) long recessed handle that is foamed-in-place with a sheet metal interlock to ensure permanent attachment.
- Positive seal doors swing within cabinet dimensions.
- Magnetic door gaskets of one piece construction, removable without tools for ease of cleaning.
- Four (4) adjustable, heavy duty PVC coated wire shelves. Two (2) right door shelf dimensions are 23 5/8" L x 28" D (601 mm x 712 mm). Two (2) left door shelf dimensions are 17 1/4" L x 28" D (439 mm x 712 mm). Four (4) chrome plated shelf clips included per shelf.
- Shelf support pilasters made of same material as cabinet interior; shelves are adjustable on 1/2" (13 mm) increments.

MODEL FEATURES

- Evaporator is epoxy coated to eliminate the potential of corrosion.
- NSF/ANSI Standard 7 compliant for open food product.

ELECTRICAL

- Unit completely pre-wired at factory and ready for final connection to a 115/60/1 phase, 15 amp dedicated outlet. Cord and plug set included.



115/60/1
NEMA-5-15R

OPTIONAL FEATURES/ACCESSORIES

Upcharge and lead times may apply.

- 6" (153 mm) standard legs.
- 6" (153 mm) seismic/flanged legs.
- 2 1/2" (64 mm) diameter castors.
- 3" (85 mm) diameter castors.
- Single overshef.
- Double overshef.
- 32 1/8" (816 mm) deep, 1/2" (13 mm) thick, white polyethylene cutting board. Requires "L" brackets.
- 32 1/8" (816 mm) deep, 1/2" (13 mm) thick, composite cutting board. Requires "L" brackets.
- Half bun tray rack (excludes left door). Holds up to eleven 18"L x 26"D (458 mm x 661 mm) sheet pans (sold separately).
- Additional shelves.
- Heavy duty, 16 gauge tops.
- Heavy duty package - 16 gauge tops, 20 gauge door, sides and back with stainless interior.
- Exterior digital temperature display (factory installed).
- Barrel locks (factory installed).

PLAN VIEW

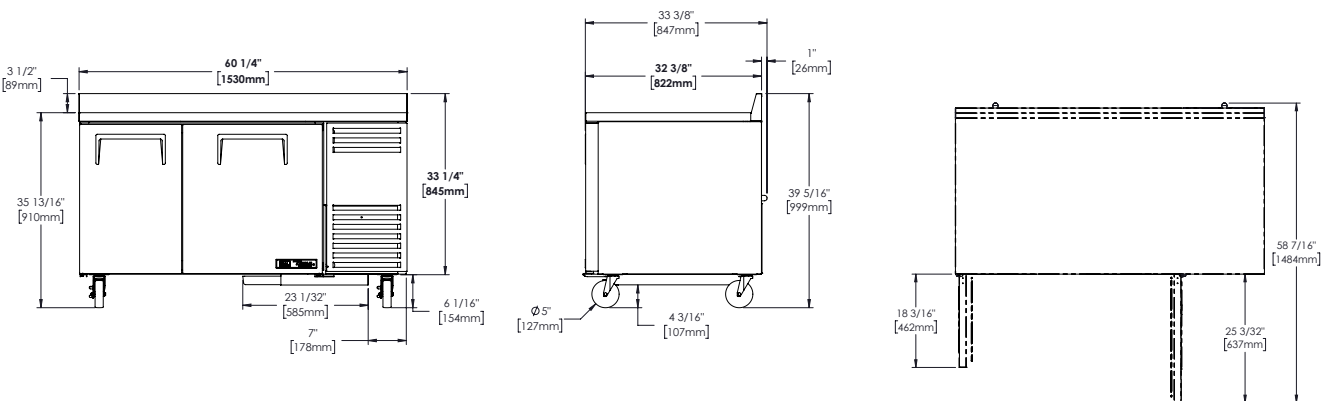

METRIC DIMENSIONS ROUNDED UP TO THE NEAREST WHOLE MILLIMETER

SPECIFICATIONS SUBJECT TO CHANGE WITHOUT NOTICE



Model	Elevation	Right	Plan	3D	Back
TWT-60-32F-HC					

TRUE MANUFACTURING CO., INC.

2001 East Terra Lane • O'Fallon, Missouri 63366-4434 • (636)240-2400 • Fax (636)272-2408 • Toll Free (800)325-6152 • Intl. Fax# (001)636-272-7546 • www.truefmfg.com